



Russian Academy of Sciences

Nuclear Safety Institute (IBRAE)

Assessment of stress state of Kalinin Unit 2 Containment

V.Medvedev, F.Ulyanov,
A.Kiselev, A.Kiselev, V.Strizhov

Sixth International Information Exchange Meeting

8-12 April 2002, Kiev



Computer Code CONT

- Designed for numeric simulation of concrete containment behavior under quasi-static operational and accident loads
- Program capabilities:
 - ◆ Non-linear elastic and plastic problems
 - ◆ Reinforcement and prestressing
 - ◆ Cracking of concrete
 - ◆ Temperature distribution
- Realization:
 - ◆ 2D Axial symmetry model
 - ◆ 3D model with the use of superelements
- Certified in the Gosatomnadzor of RF



CONT Code Verification

- Verification against analytical problems
- Validation against experimental data:
 - ◆ Small scale model experiments conducted in Russia
 - ◆ 1:6 Sandia reinforced containment test
 - ◆ 1:4 Sandia prestressed containment tests (in progress)
- Comparison to NPP data (Kalinin VVER-1000)



Kalinin-2 NPP Containment Main Geometrical parameters

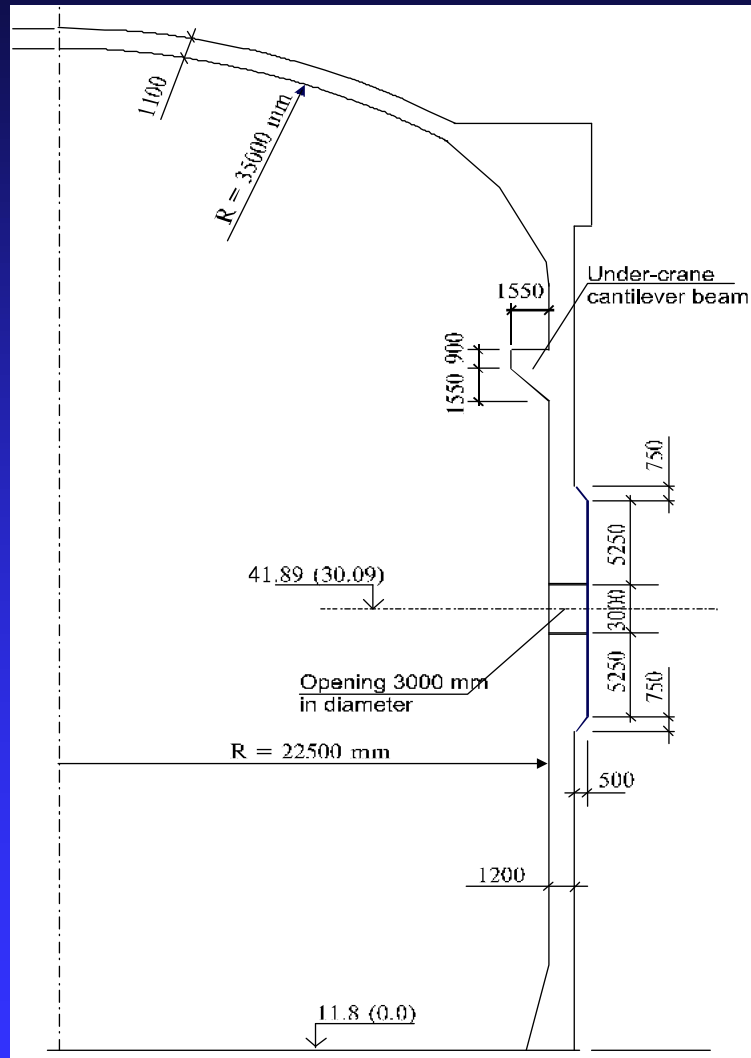

- Main design peculiarities of the containment
 - ◆ Geometry of the containment
 - ◆ Reinforcement
 - ◆ Prestressing system
- Methodology of analysis for prestressed concrete containment
- Nodalization scheme of the containment
- Results of the analysis under normal operation and accident conditions



Computational model of the Kalinin Unit-2 Containment

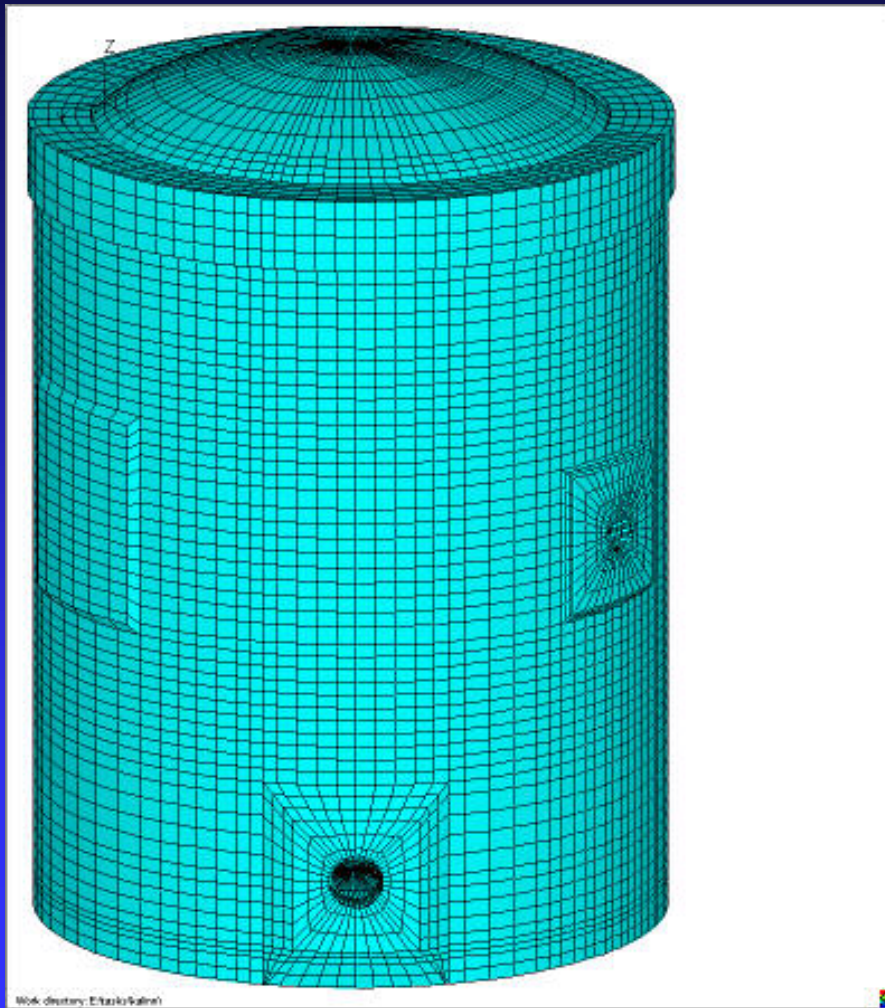

The computational model includes

67946 finite elements

and 76014 nodes



Computational model of the concrete wall

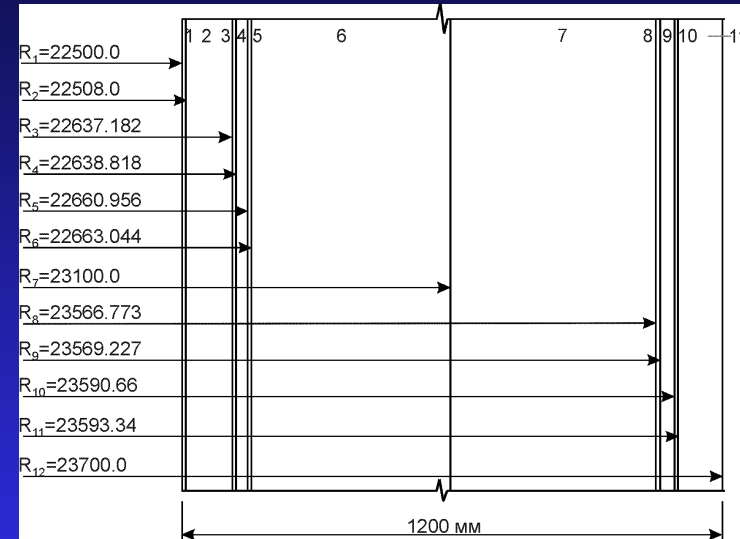
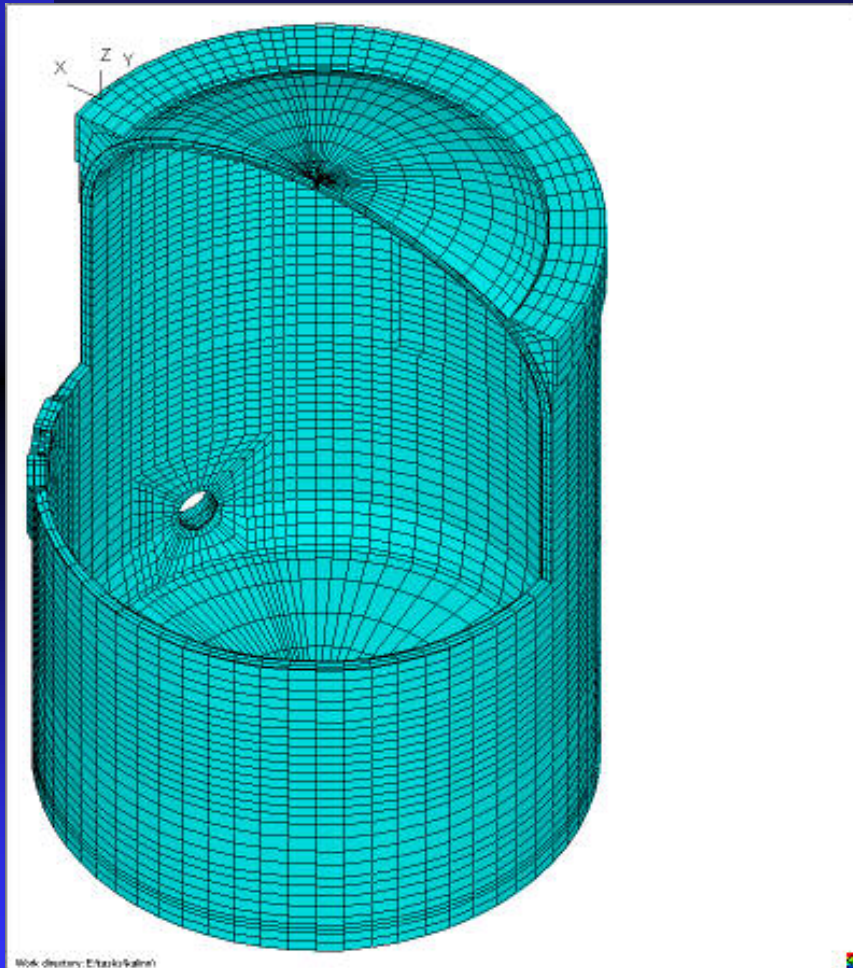

- 1 – metallic liner
- 2, 4, 6, 7, 9, 11 – concrete layers
- 3, 10 – meridian reinforcement
- 5, 8 – hoop reinforcement



Scheme of the reinforcement in the middle of cylindrical part of containment

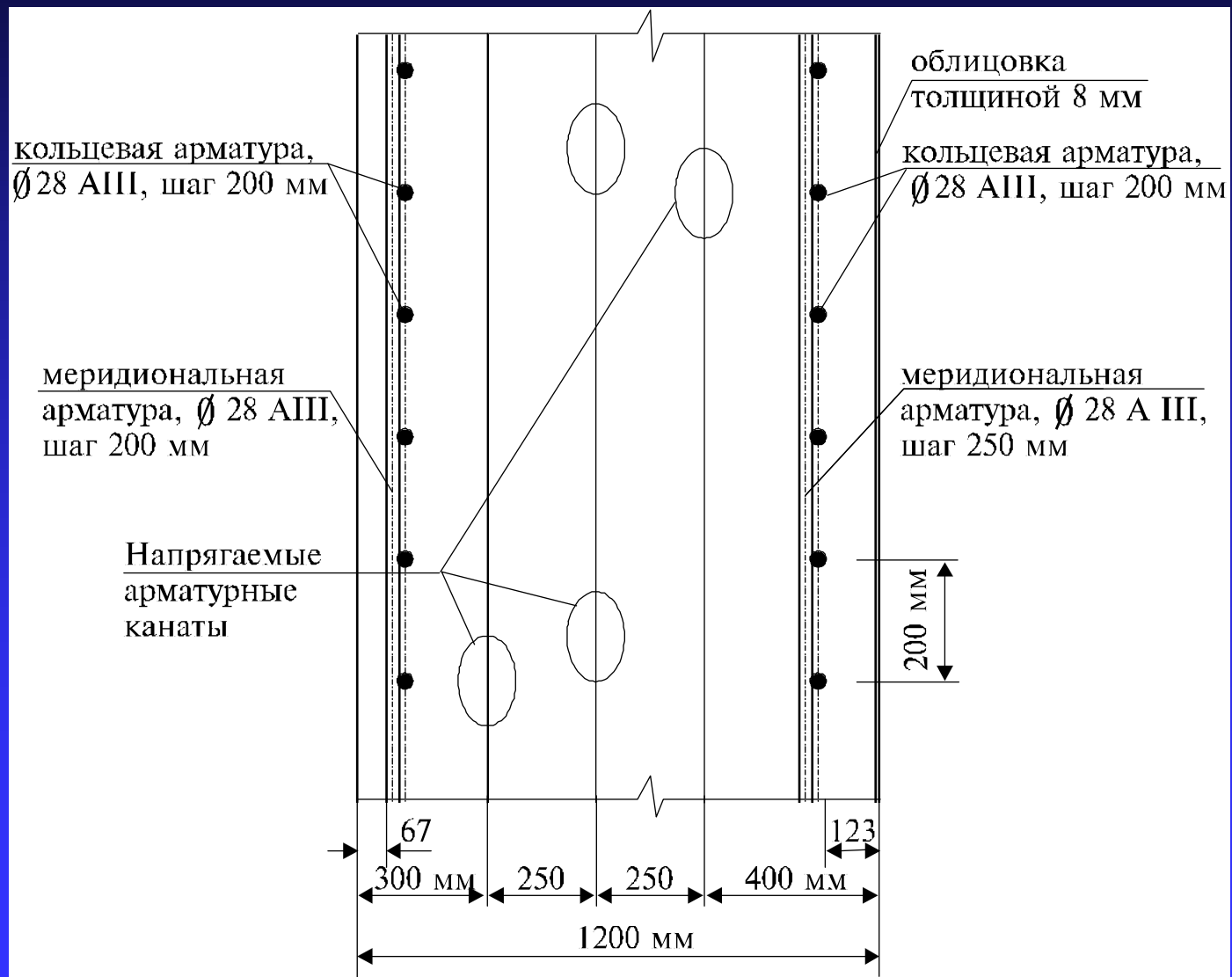



Location of tendons in the cylindrical part of Kalinin-2 containment

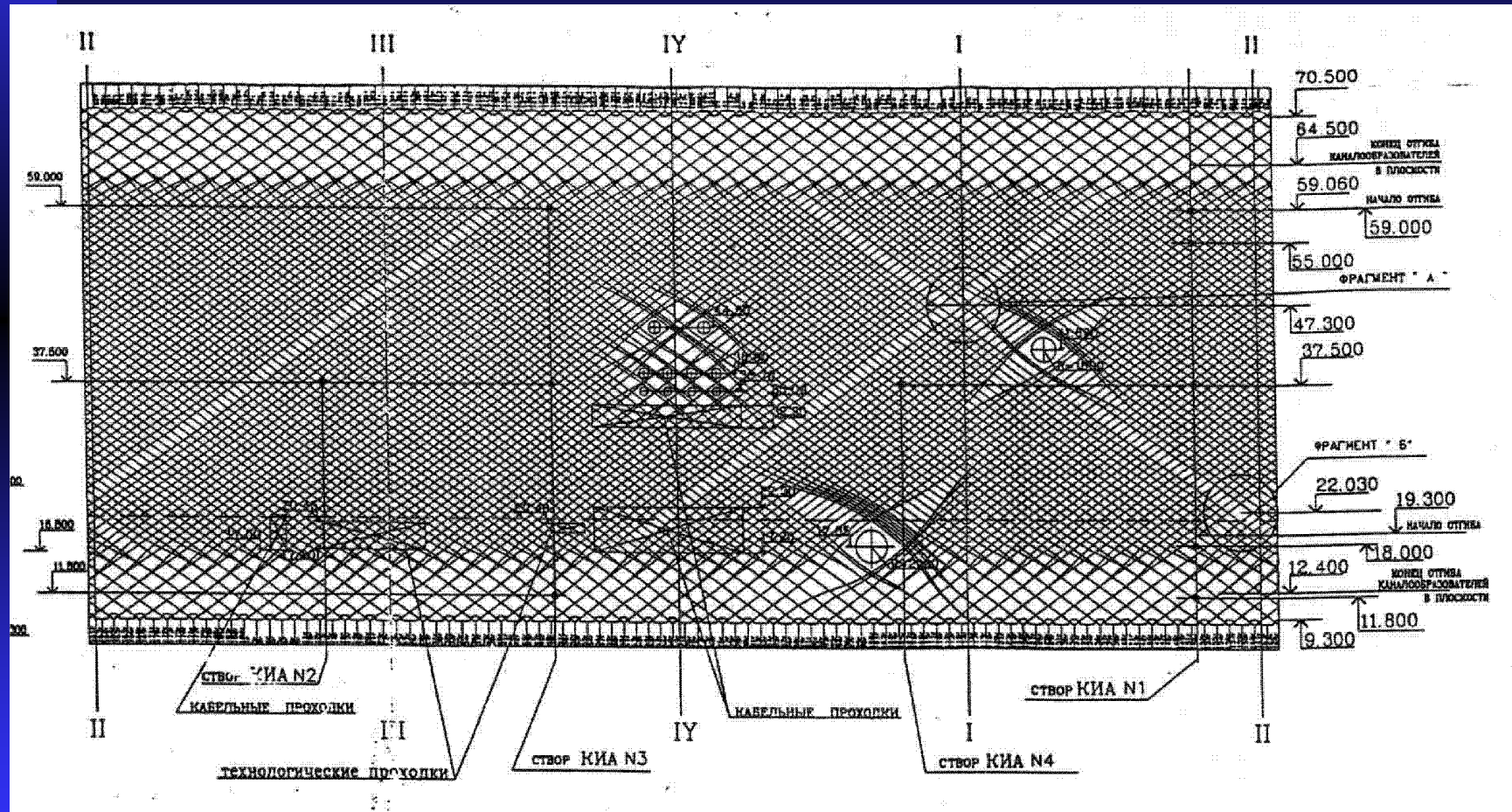



Methodology of analysis

Factors considered:

- Concrete cracking in case of reaching ultimate stretching strengths
- Presence of internal metallic liner
- Concrete reinforcement including its strengthening in the areas of stress concentration

Loads considered:

- Tendons prestressing
- Inherent weight of containment
- Thermostresses due to non-steady state temperature gradients under operational and accident conditions
- Variation of internal pressure in course of accident



Peculiarities of simulation prestressing of tendons

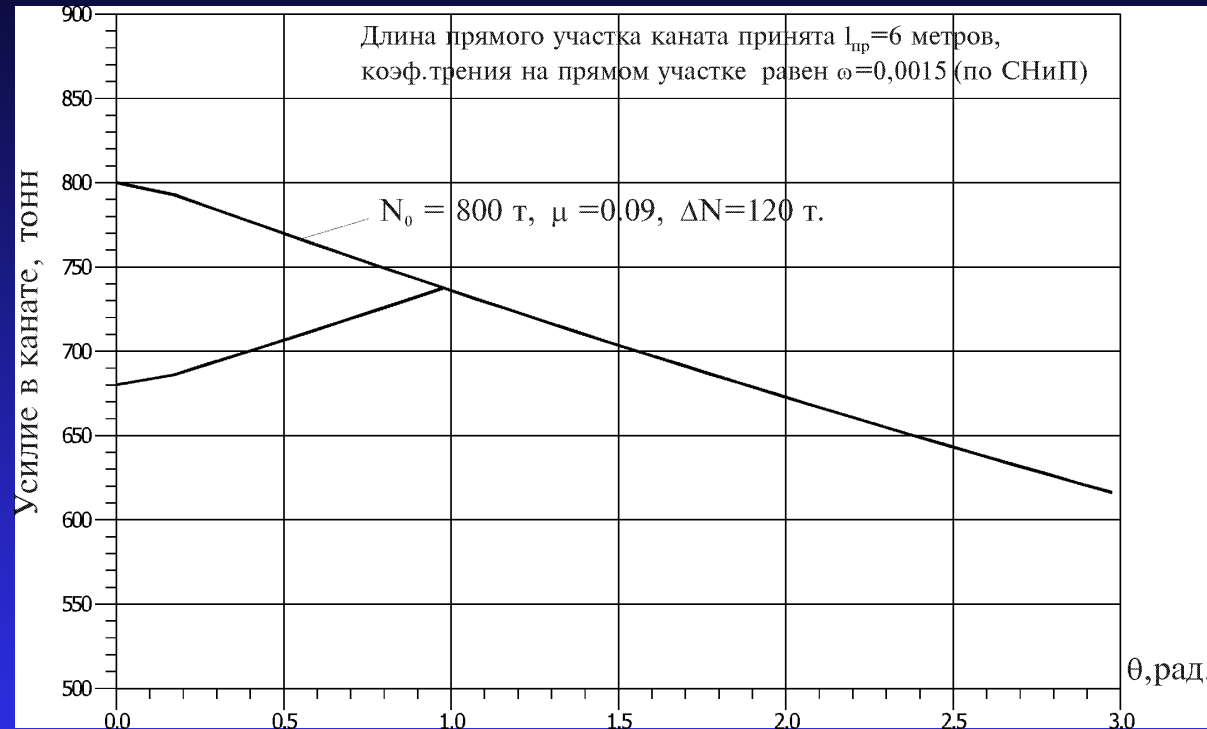

- Real tendons trajectories
- Strength reduction along tendons due to friction
- Strength reduction from the jack to anchor
- Real strength of tendons according to plant data



Stresses in liner (internal surface) and concrete (outer surface) due to inherent weight (MPa)

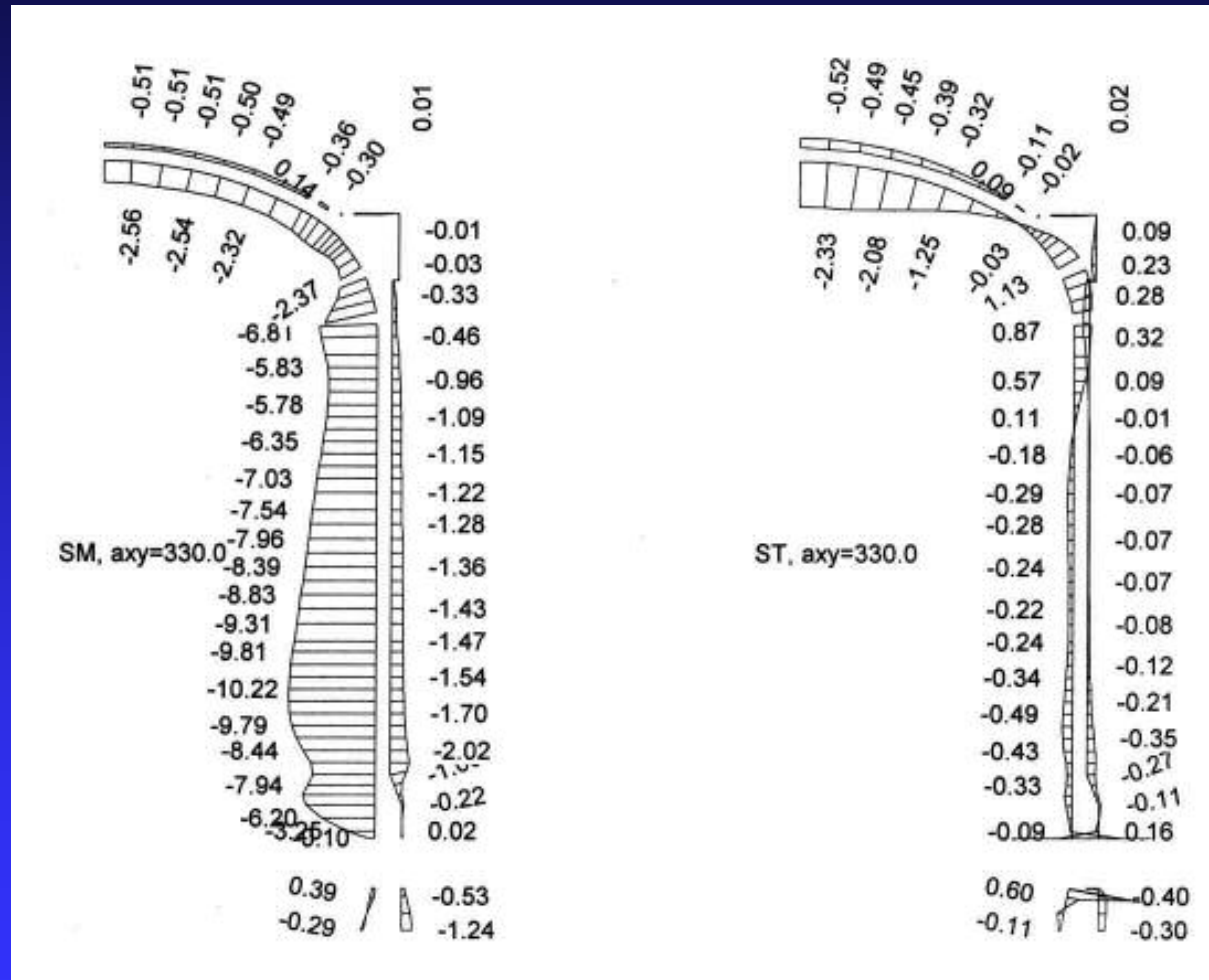

Meridian stresses (SM)

Hoop stresses (ST)



Deformation of containment due to prestressing of tendons

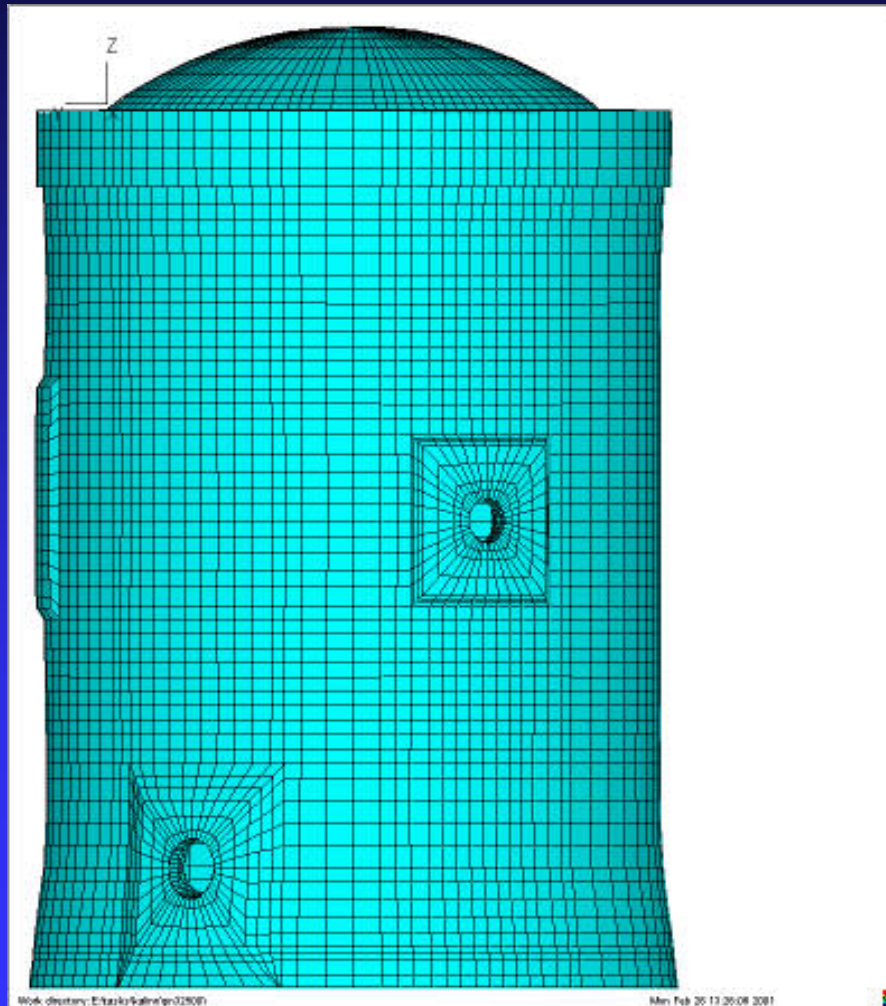

- Real strengths in tendons were applied
- Scale factor for deformations 500



Meridian stresses in the concrete due to prestressing of tendons

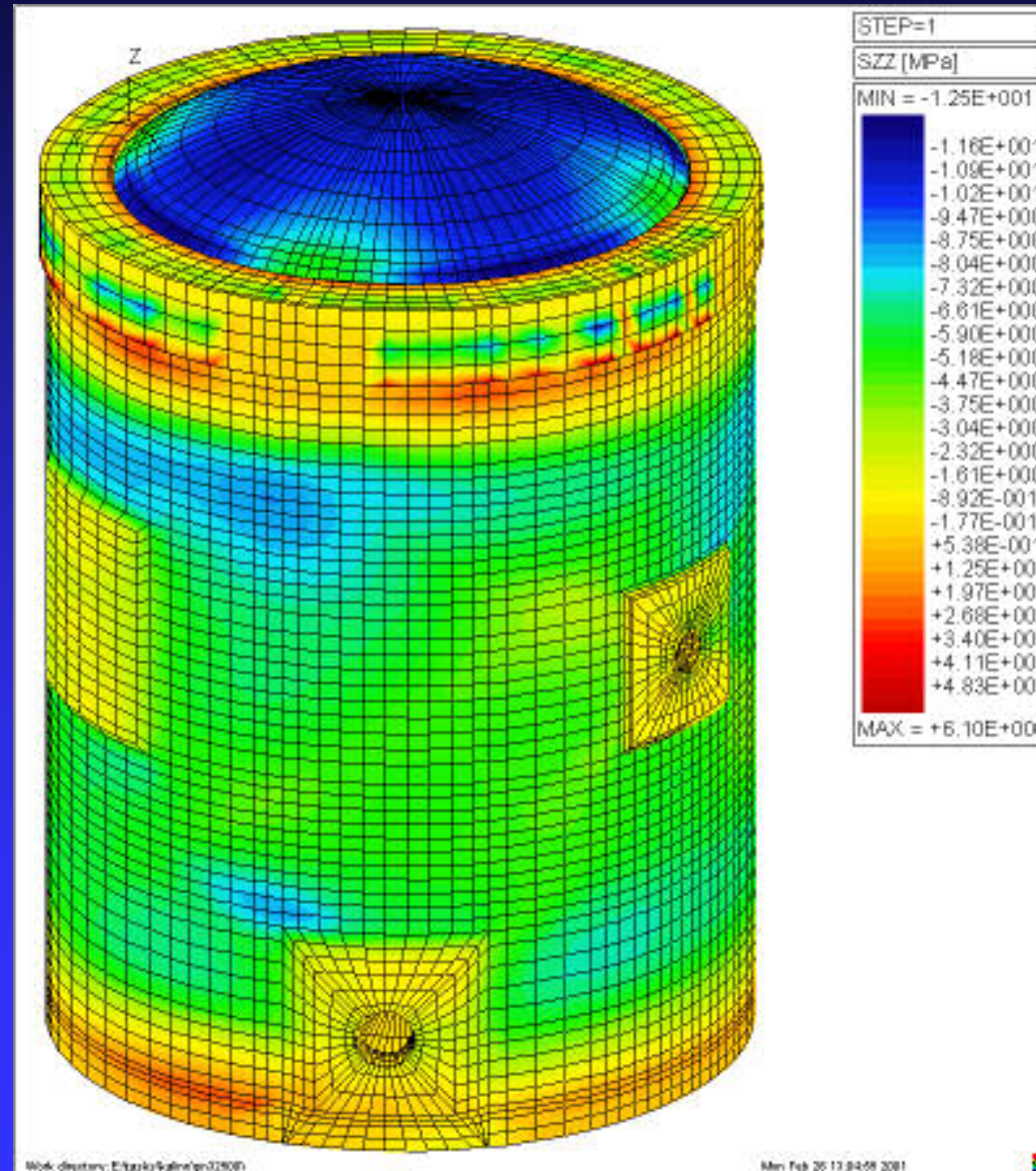



Hoop stresses in the concrete due to prestressing of tendons

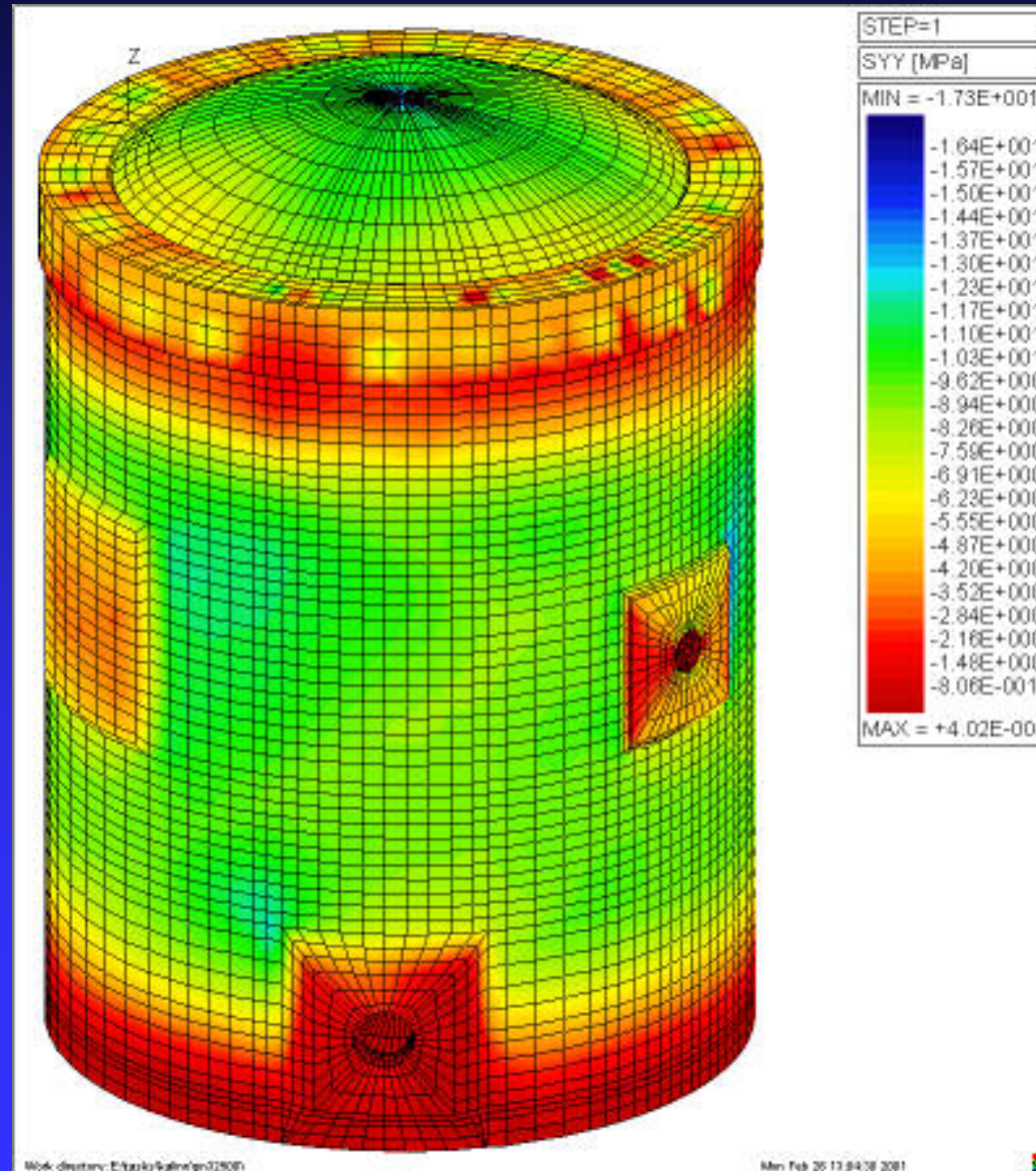



Stresses in liner (internal surface) and concrete (outer surface) due to internal pressure 1 MPa

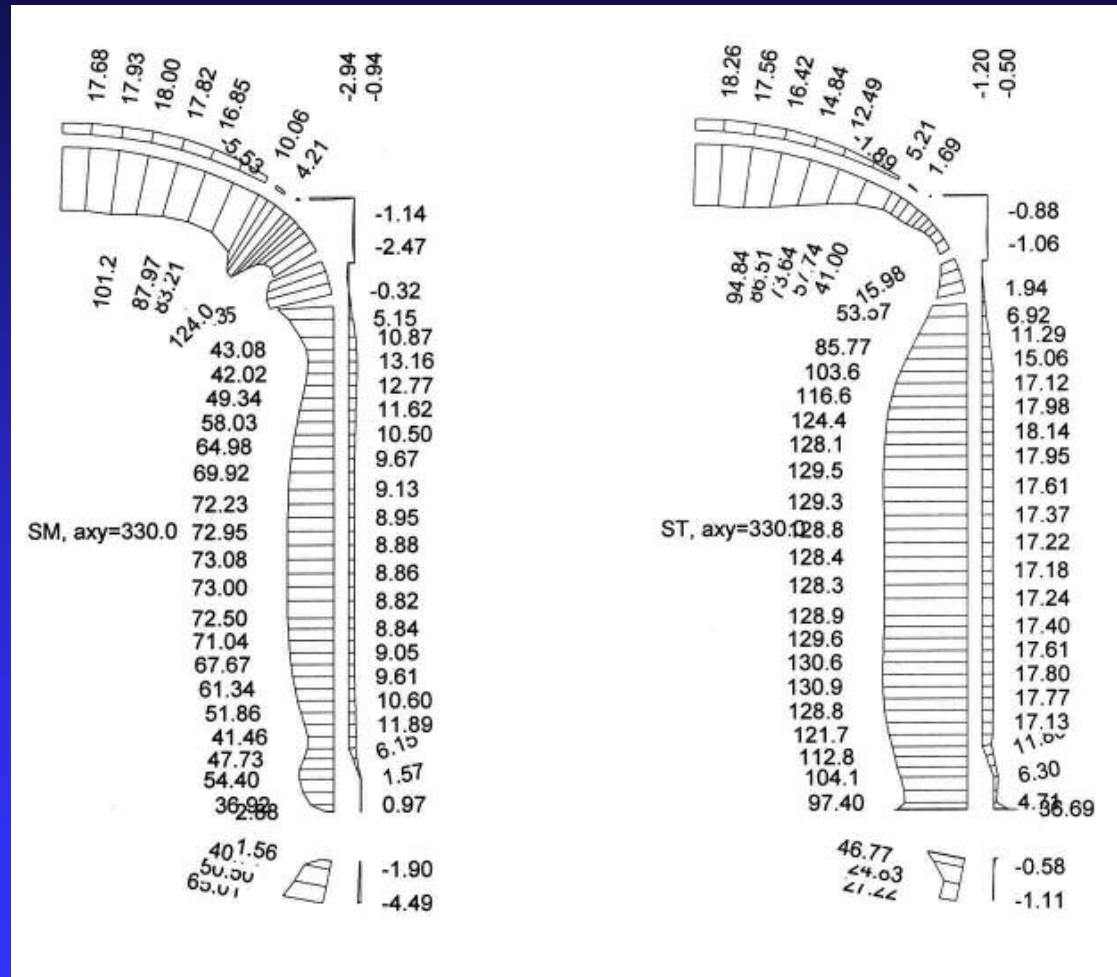

Meridian stresses (SM)

Hoop stresses (ST)



Temperature distribution in the concrete in normal operation conditions

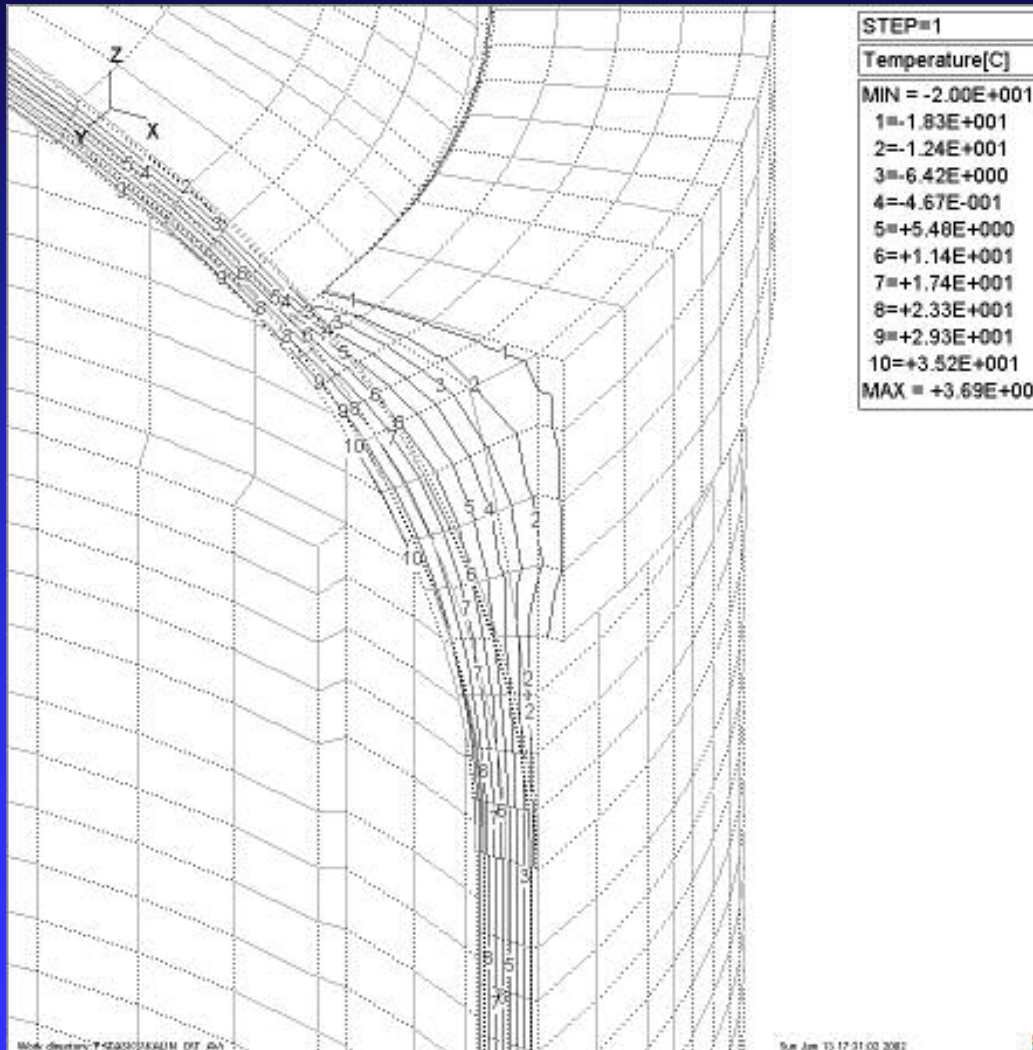

Inside
temperature
+40 °C

Outside
temperature
-20 °C



Stresses in liner (internal surface) and concrete (outer surface) due to operational temperature

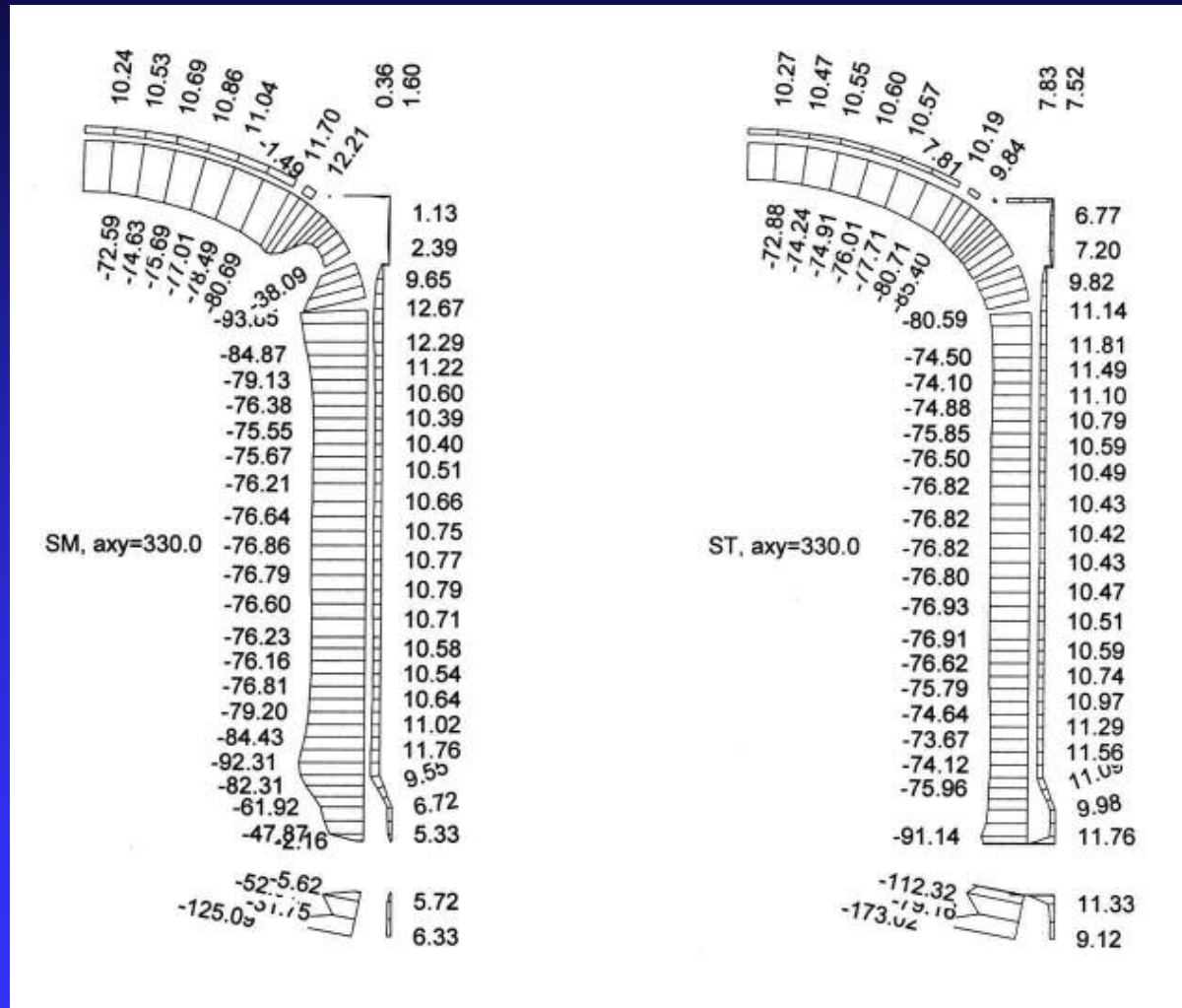

Meridian stresses (SM)

Hoop stresses (ST)



Calculated temperature variation at different location in the time interval between 13.09.99 through 29.12.99 at different depths

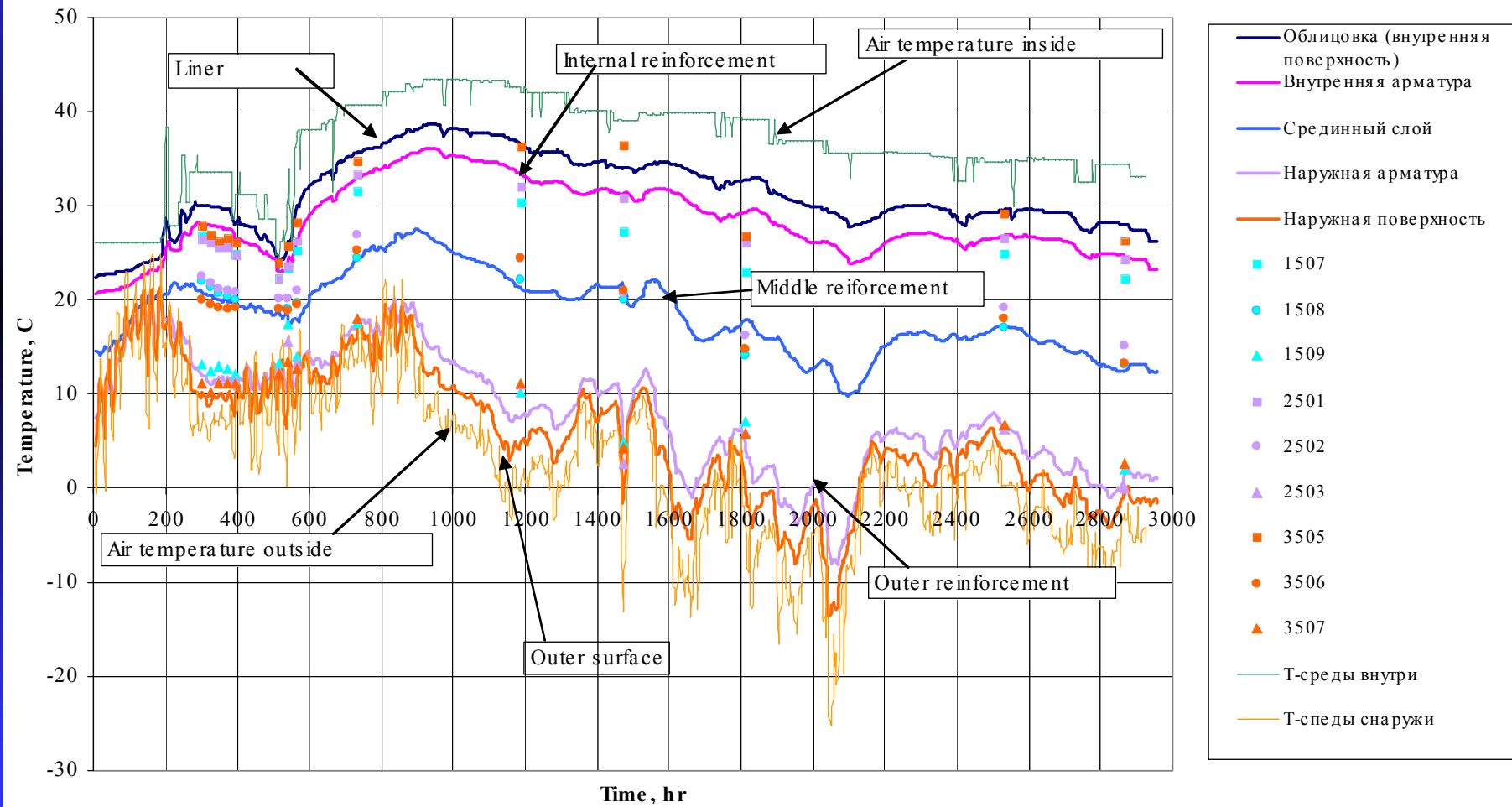



Temperature distribution through containment wall on 29.12.1999 with the account of inside and outside temperature variations

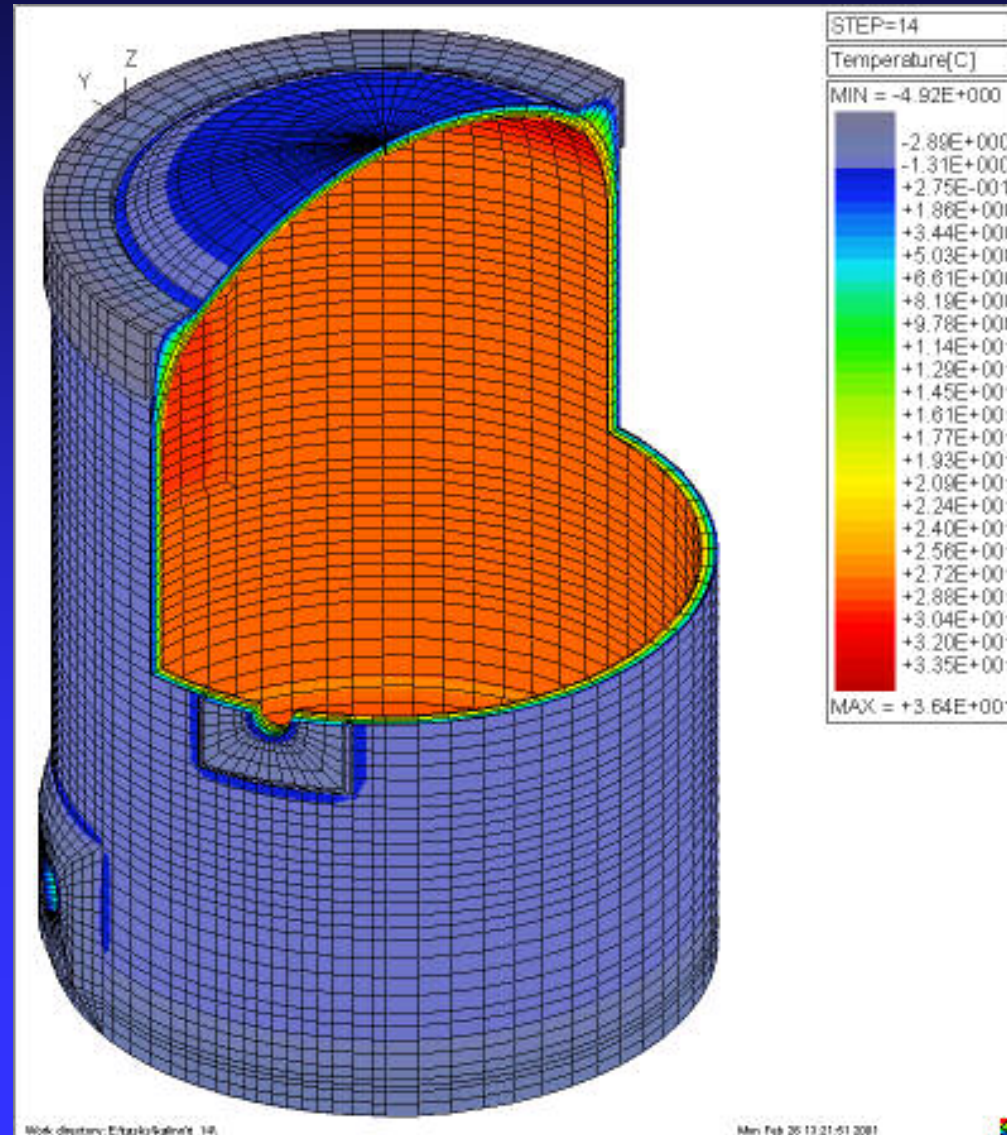



Hoop stresses in the concrete due to temperature gradients

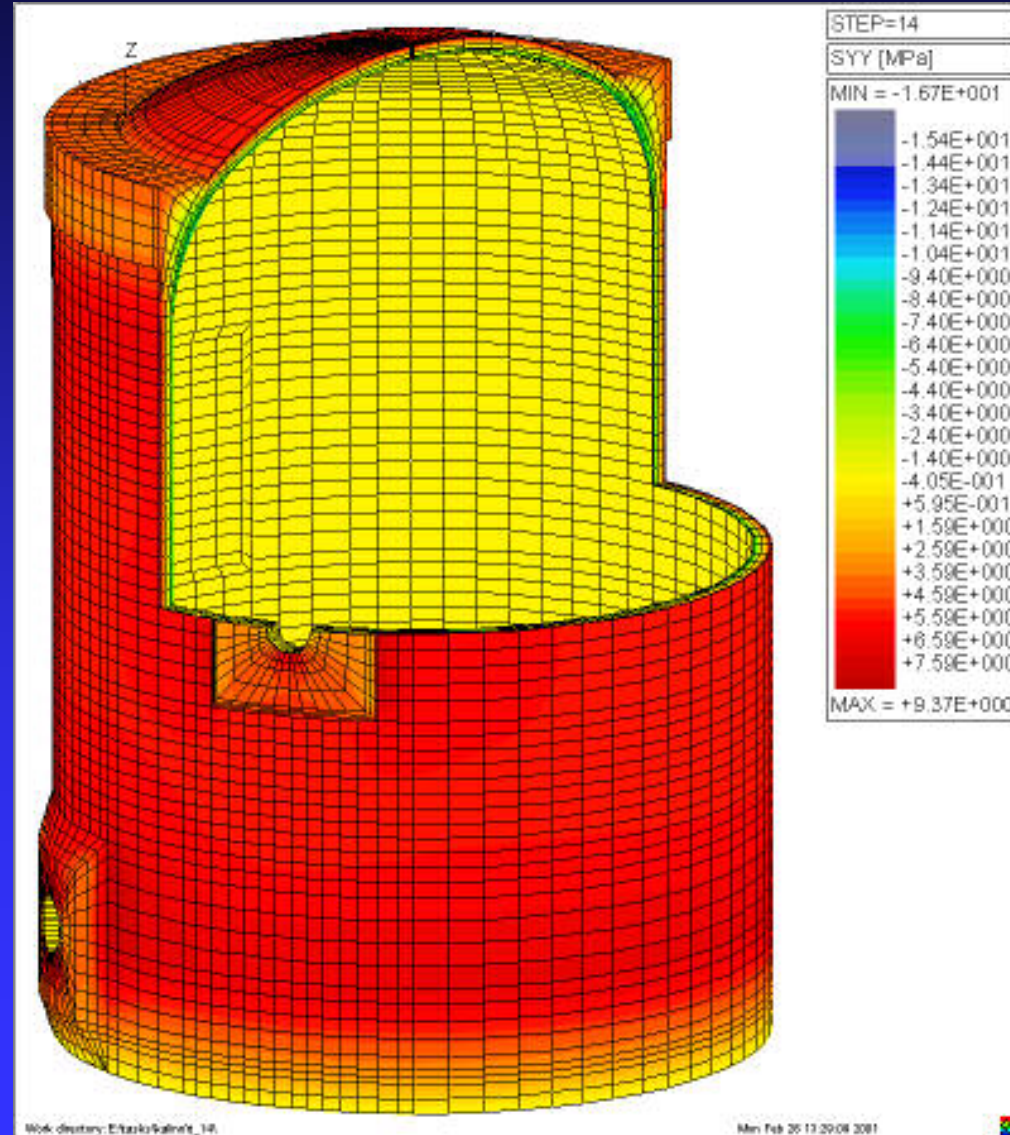



Variation of temperature and pressure in the containment for design accident

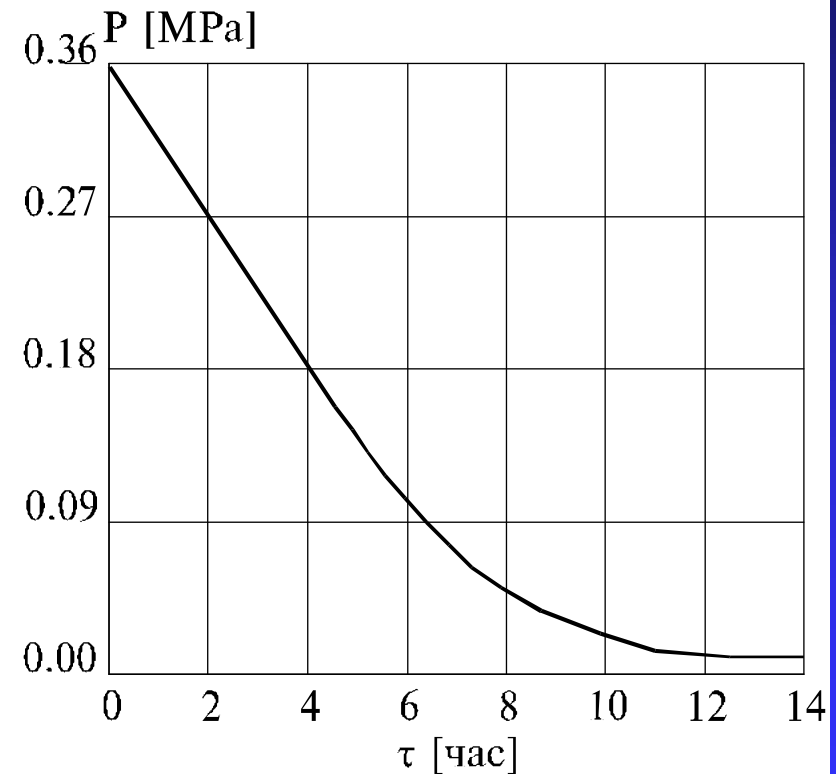
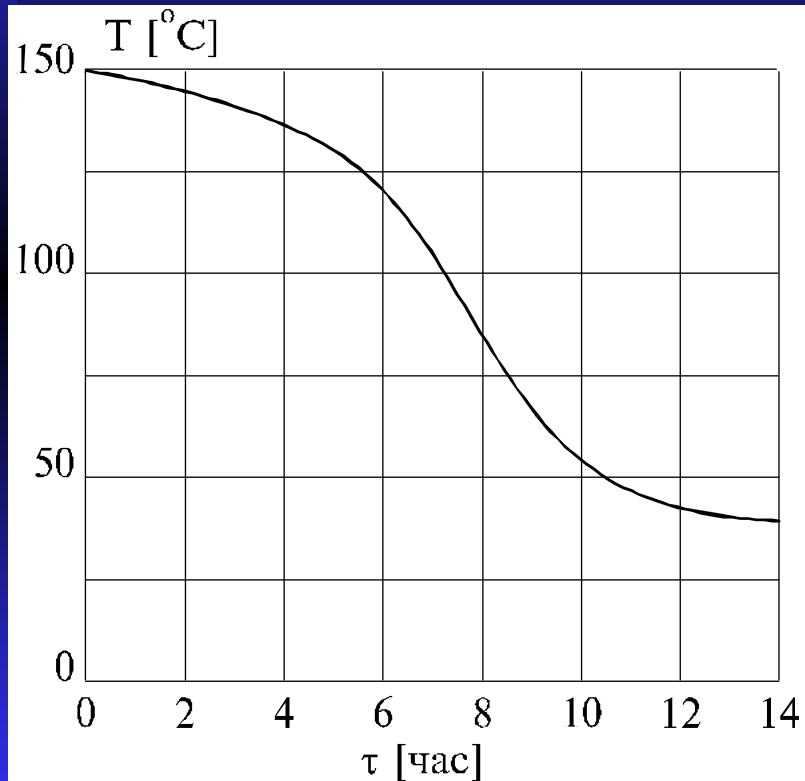

t - time (hr) from accident



Stresses in liner (internal surface) and concrete (outer surface) due to operational temperature

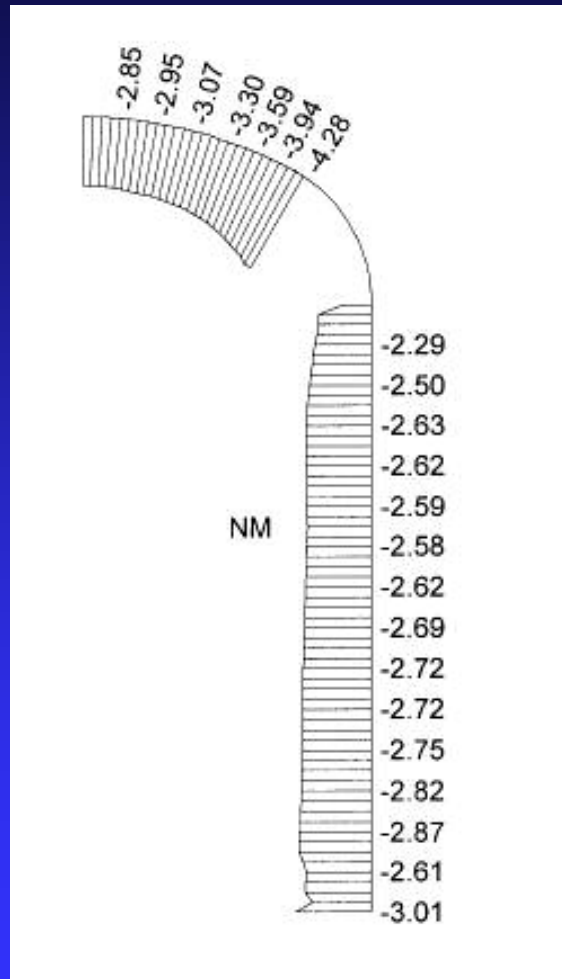

Meridian strength (SM)

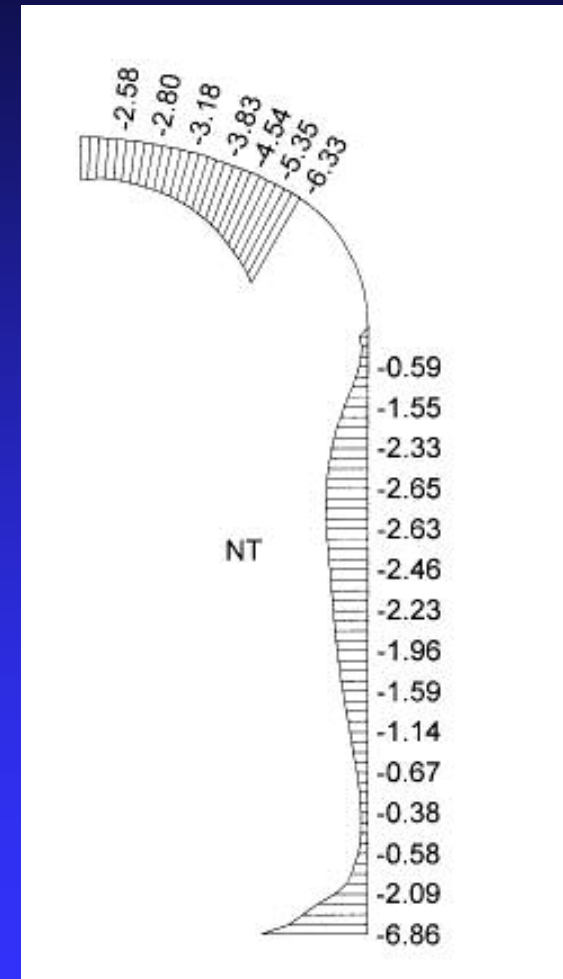

Hoop strength (ST)



Meridian and hoop strength [MN] in the horizontal sections, $Z=25$ m (a) и $Z=60.5$ m (b) at the initial time instant

a)

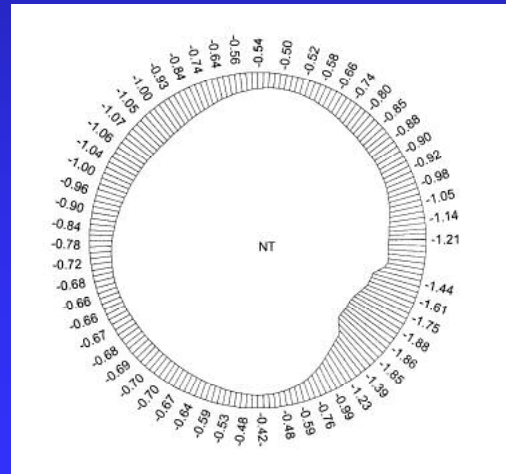
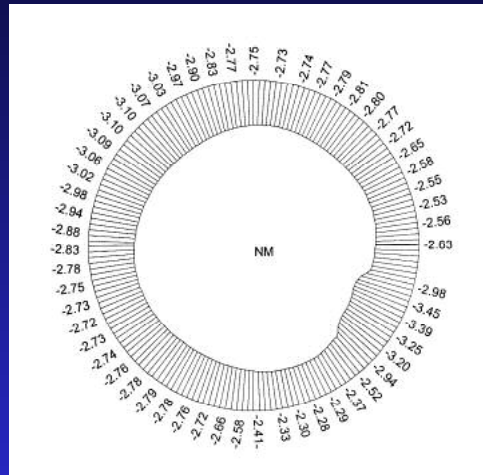

b)

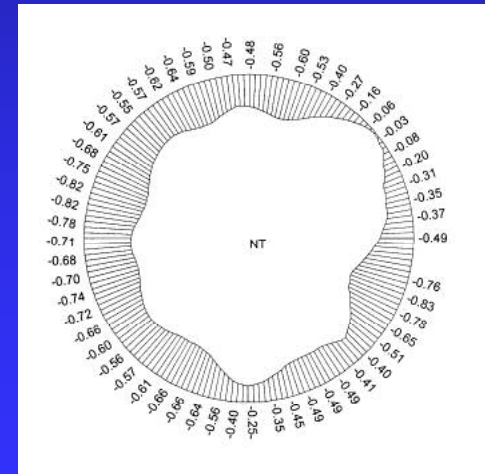
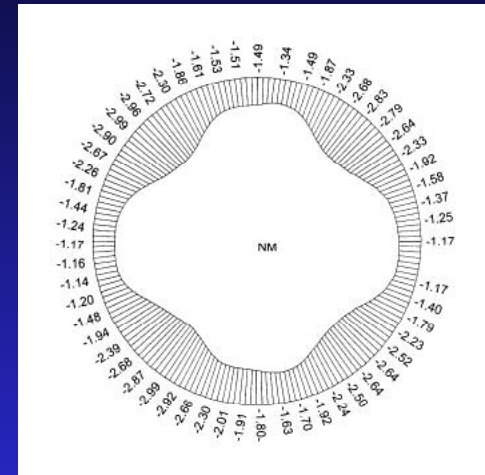



Conclusions

- The state of the Kalinin Unit 2 containment is at the reasonable level under actual strength (800 tones) both for operational and accident conditions
- The CONT code allows to account for a number of factors influencing stress-strain state of the containment under operational and accident loads
- Assessments performed with the CONT code allows to develop methodology of operational safety control accounting for actual state of prestressing tendons which require strengthening to recover necessary prestressing level