

Sixth International Information Exchange Forum  
on  
“Safety Analysis for Nuclear Power Plants of VVER and RBMK Types”  
(Forum-6)  
to be held 8-12 April 2002; Kiev, Ukraine

**Pipe Whip Transient Analysis of the Ignalina NPP**

G. Dundulis, R. Kulak,\* A. Marchertas,\* M. Petri,\* E. Uspuras  
Lithuanian Energy Institute, Lithuania  
\*Argonne National Laboratory, USA

**ABSTRACT**

Presented in this paper is the transient analysis of a Group Distribution Header (GDH) following a guillotine break at the end of the header. The GDH is the most important component of reactor safety in case of accidents. Emergency Core Cooling System (ECCS) piping is connected to the GDH piping such that, during an accident, coolant passes from the GDH into the ECCS.

The GDH that is propelled into motion after a guillotine break can impact neighboring GDH pipes or the nearest wall of the compartment. Therefore, two cases are investigated:

- GDH impact on an adjacent GDH and its attached piping;
- GDH impact on an adjacent reinforced concrete wall.

A whipping RBMK-1500 GDH along with neighboring concrete walls and pipelines is modeled using finite elements. The finite element code NEPTUNE used in this study enables a dynamic pipe whip structural analysis that accommodates large displacements and nonlinear material characteristics. The results of the study indicate that a whipping GDH pipe would not significantly damage adjacent walls or piping and would not result in a propagation of pipe failures.

**INTRODUCTION**

The Ignalina Nuclear Power Plant (NPP) is a twin unit with two RBMK-1500, graphite moderated, boiling water, multi-channel reactors. RBMK-type reactors contain thousands of pipelines. Sometimes several high-energy pipelines are located in one compartment. A guillotine rupture of one of these high-energy pipelines raises serious safety concerns about severe damage to neighboring pipelines and to the building structures. In order to understand the extent of damage from pipe ruptures, it is important that analyses be performed to verify that adjacent piping and reinforced concrete walls have sufficient strength to endure the dynamic loading from a whipping pipe that was generated during a maximum design accident.

The GDH is one of the most important components for the reactor safety. GDH is important component not only during the normal operation, but also in case of accident. ECCS piping is connected to GDH piping. In case of accident coolant passes through the ECCS and GDH piping.

The location of GDH break was selected taking into account geometry of GDH, possibility of guillotine rupture, location of zones where defect detection is difficult, locations of GDH supports, the thermal-hydraulic consequences of a break and recommendation of Safety Analysis Report [1].

The part of GDH located in compartment of the GDH and lower water communication was selected for the analysis. There are many pipes in this compartment. Besides, it is very difficult to use non-destructive equipment for detecting cracks in welds. Two welds of each GDH are in

this compartment – one near to the support wall (950 mm from wall) and another - at the end of the GDH. One circumferential defect (length 100 mm, depth 11mm) had been detected in the GDH cap weld at Ignalina NPP. Circumferential defects around the GDH tube diameter have also been detected at the Chernobyl NPP. No circumferential defects had been detected in the weld near to the wall (950 mm from wall).

Transient analysis of the GDH guillotine break and impact to neighboring pipes and walls was carried out. Results of this analysis are presented in this paper.

The finite element code NEPTUNE was used in this analysis. Validation of the NEPTUNE computer code for pipe whip analysis was presented in reference [2].

## DATA FOR THE GDH WHIP ANALYSIS

### *Geometrical Models*

The GDH pipes are located in the GDH compartment. The top view of the GDH compartment is presented in Fig. 1. The distance between two GDH pipelines, GDH pipeline and wall is small. Therefore, the subject of the investigation is (a) the collision between two adjacent GDH pipelines (including lower water communications connected to GDH pipe) and (b) the collision between the GDH pipe and the nearest wall. Structural integrity of the GDH supporting wall is also important. Therefore, the GDH pipes 3 and 4, and the walls 1 and 2 (Fig. 1) are included in the model of GDH whip analysis.

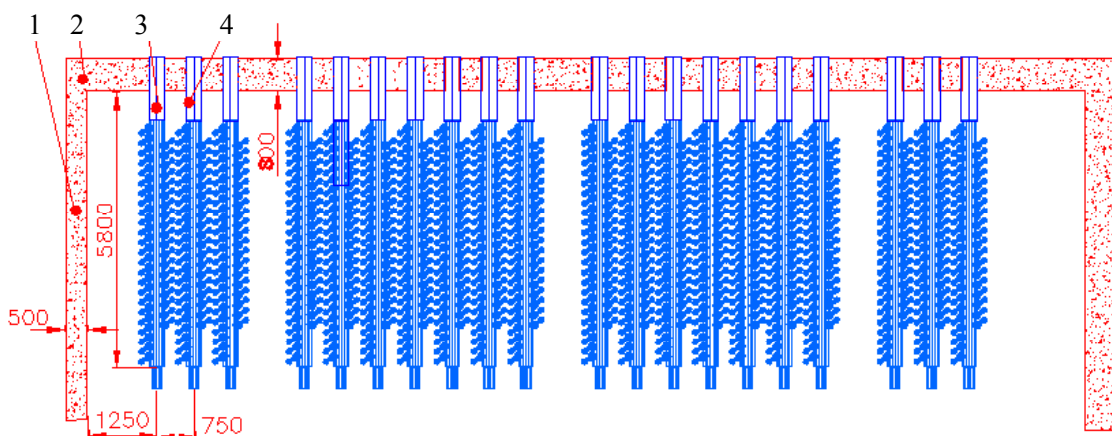

Fig. 1. Top view of the GDH in the compartment

Group distribution header is a horizontal cylinder with outside diameter of 325 mm, wall thickness – 15 mm, and its length – about 5 m. Figure 2 shows the cross-section of the GDH. There are a total of 40 GDHs (20 GDHs per loop) in one unit of the Ignalina NPP. One end of the GDH cylinder is connected to pressure piping, the other to the end with a cap. The piece of pipe connected to the GDH cap is fastened to a roller bearing (Fig. 2). Thus, the axial expansion of the GDH is not constrained. Also, the support of the end of the GDH has a guard structure.

Each header distributes coolant to from 40 to 43 of Low Water Communication (LWC) pipes (57x3.5 mm). These pipes are provided with isolation and control valves between the GDH outlet and the entrance to the fuel channel. Isolation and control valves are used to adjust channel flow on the basis of channel power.

The final model contains LWC lines and concentrated masses representing isolation and control valves. The concentrated masses were attached to the points of the LWC lines where isolation and control valves are connected. The GDH pipe, displaced after guillotine break, can impact the neighboring GDH pipe or the nearest wall of the compartment. Therefore, two cases were investigated:

- GDH impact on adjacent GDH (Fig. 3a);
- GDH impact on adjacent wall (Fig. 3b).

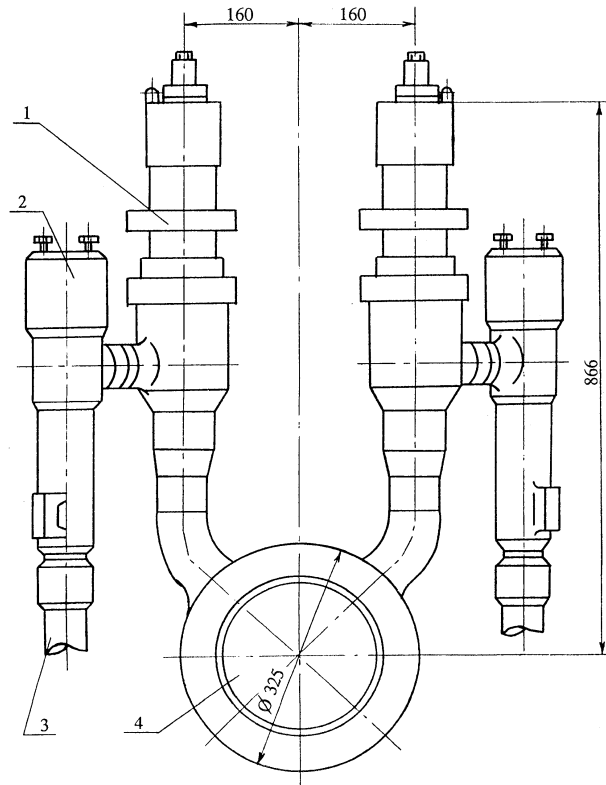

a)

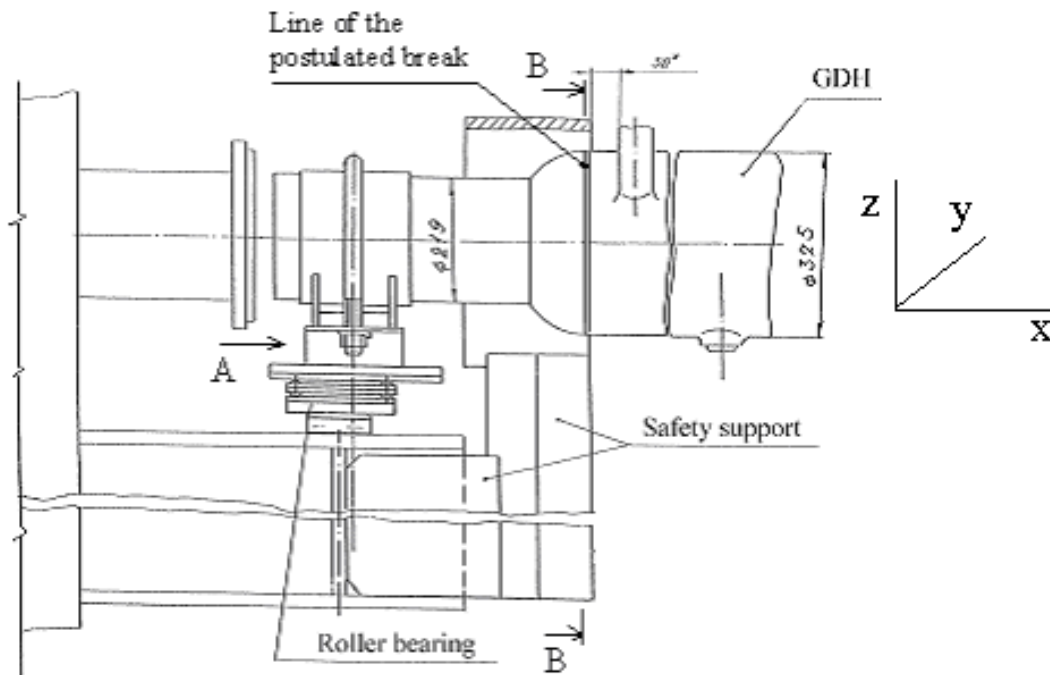

b)

Fig. 2. a) Cross section of the GDH: 1- isolation and control valve, 2 – ball type flow-rate meter, 3 – pipeline leading to the fuel channel, 4 - group distribution header; b) End support of the GHD

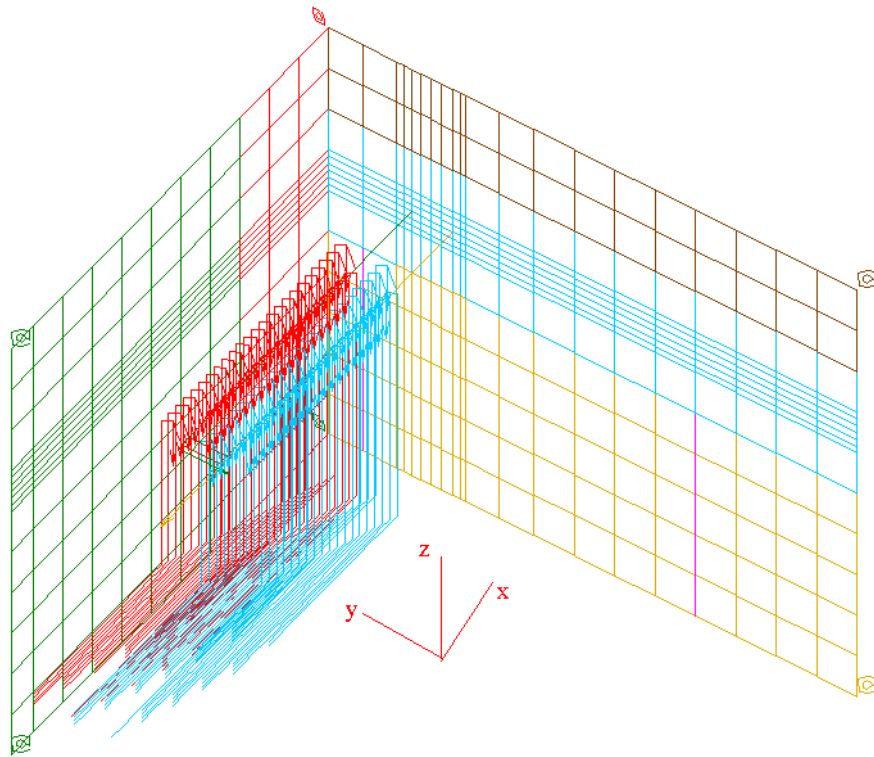

a)

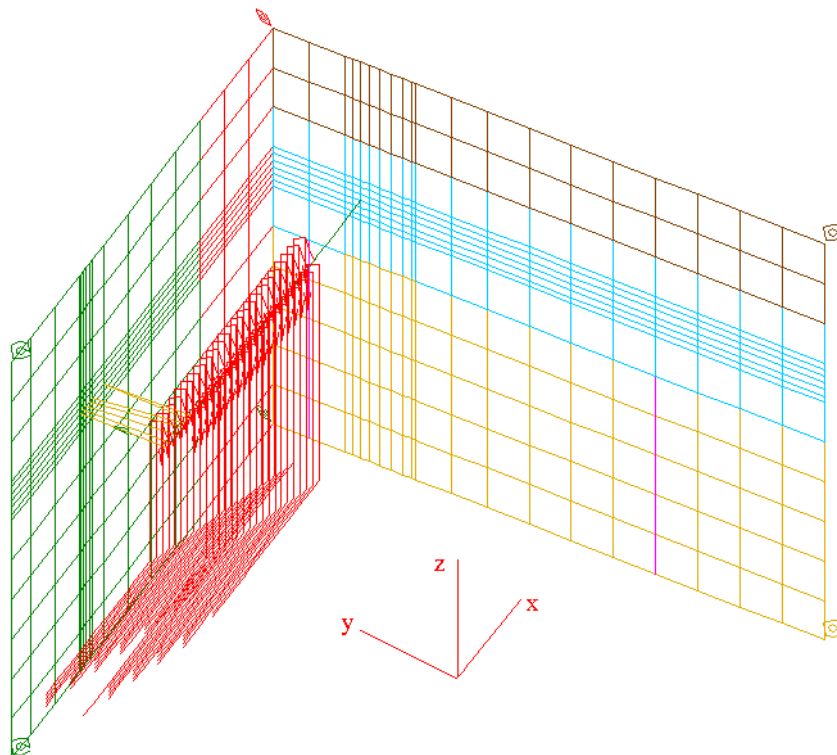

b)

Fig. 3. Combined schematic models of the GDH pipes, connected LWC pipes with concentrated masses of isolation and control valves, and concrete walls for investigation of impact to: a) adjacent GDH and, b) reinforced concrete wall

## Modeling of Reinforced Concrete Walls and Pipes by Finite Elements

The NEPTUNE code is based upon the central difference explicit integrator. Thus, the code does not employ stiffness or flexibility matrices but is based upon a nonlinear internal nodal force vector. This approach is ideal for transient, nonlinear analyses in which metals are deforming in an elastoplastic mode, concrete is cracking/crushing and contact impact is taking place. When individual elements reach a failed state, their contributions to the internal nodal force vector is reduced to zero and there is no change required to the solution algorithm.

Compartment walls were modeled using the four-node quadrilateral plate element developed by Belytschko, et al. [3] The formulation of this element is based upon the Mindlin theory of plates and uses a velocity strain formulation. The material model can treat elastoplastic behavior. Kulak and Fiala [4] expanded the formulation by incorporating the ability to model a composite plate of reinforced concrete. Subsequently, additional failure criteria were added, and this enabled the modified elements to model concrete cracking, reinforcing bar failure and gross transverse failure.

GDH and LWC pipelines were modeled using three-dimensional pipe elements. For the global solution of a pipe whip event, the use of pipe element capable of undergoing large displacements in three-dimensional space were required. The pipe element used in the NEPTUNE code was an enhanced version of a beam/pipe element developed by Belytschko and Schwer [5]. The material model used can handle elastoplastic behavior. Validation of the use of the NEPTUNE code for pipe whip and impact problems was reported by Narvydas and Kulak [6] and Kulak and Narvydas [2].

For the GDH impact on adjacent GDH, and GDH impact on adjacent wall, the node-to-line contact element [7, 8] was used in this analysis. The node-to-line contact element, a triangular element, in which one node of a broken pipe element is connected to two nodes of a neighboring pipe or wall. This contact element is used for problems with simple geometry and when the contact-impact location is approximately known beforehand.

### Material Properties

Regarding material properties, the model was analyzed has two basic parts: GDH pipelines made from steel 08X18H10T and walls of the compartment made from reinforced heavy concrete M300.

Mechanical properties [9] of concrete and reinforcement bars are summarized in Table 1.

Table 1. Material Properties of Reinforced Concrete

Material	Type (Russian brand)	Young's modulus, Mpa	Poisson's ratio	Yield stress, MPa	Compressive stress (concrete) Ultimate stress (steel), MPa	Ultimate strain, %
Concrete	M300	2.7E4	0.2	8.5	17	0.35
Steel of reinforcement	A III	20.5E4	0.3	392	590	14

Standard yield strength, ultimate strength, ultimate strain, area reduction and modulus of elasticity of steel 08X18H10T are presented in Table 2.

Table 2. Material Properties of Steel 08X18H10T [10]

Characteristic	Temperature, °C							
	20	50	100	150	200	250	300	350
$R_m^T (\sigma_u)$ , MPa	510	471	461	441	421	421	412	412
$R_{p0.2}^T (\sigma_{0.2})$ , MPa	216	206	206	196	187	187	177	177
A ( $\delta$ ), %	35	32	30	28	27	26	26	26
Z, ( $\psi$ ) %	55	55	55	54	54	53	52	51

## Boundary Conditions

Certain nodes of the GDH compartment model have translation and rotation restrains that accounts for the effect of the surrounding structures. As the model is built in a rectangular (Cartesian) global coordinate system, the corner nodes (Fig. 4, symbol  $\Delta$ ) are completely restrained, translations are designated by (T) and rotations by (R). Nodes of wall edges have certain translation constrains along the X, Y, or Z-axes as shown in Fig. 4.

The LWC pipelines have several supports to prevent free motion of those pipes. Therefore, the GDH pipe model has restrains on LWC pipelines (Fig. 5). The end of the model of these pipelines has translation restrains in global Z and Y directions. In addition, the LWC lines (except 4 lines at the end of GDH) have restrains in the X and Y direction 2.75 m. below the axis of the GDH. The model with the LWC restrains is shown in Fig. 5.

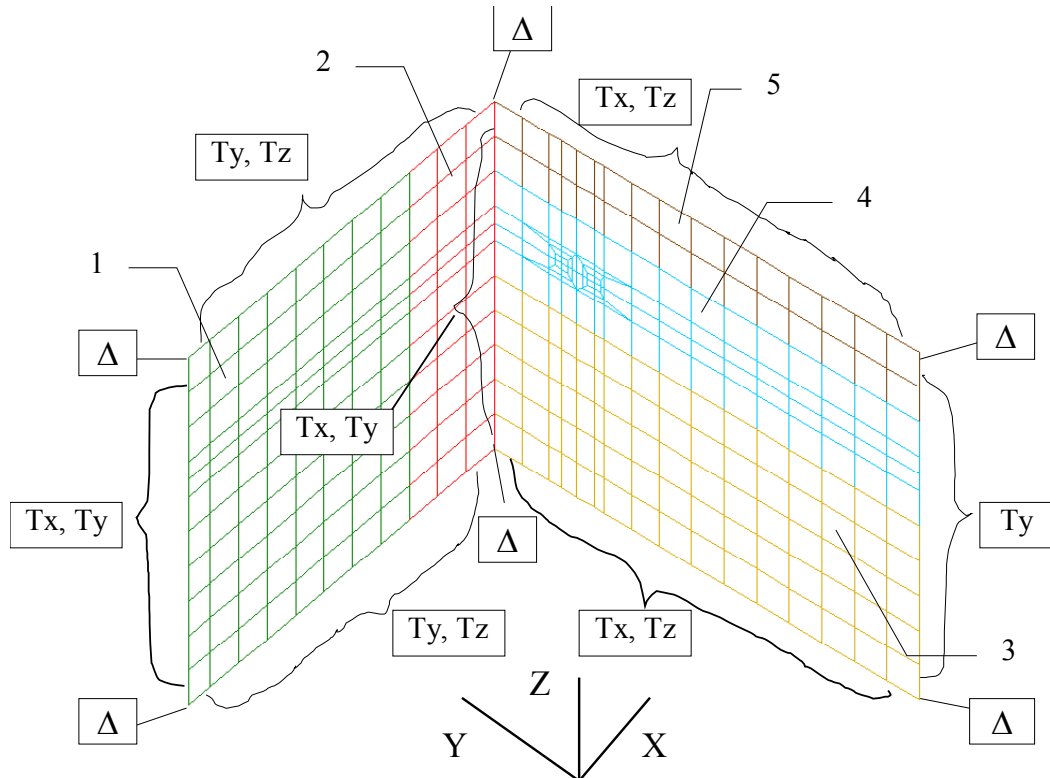

Fig. 4. Walls of the GDH compartment

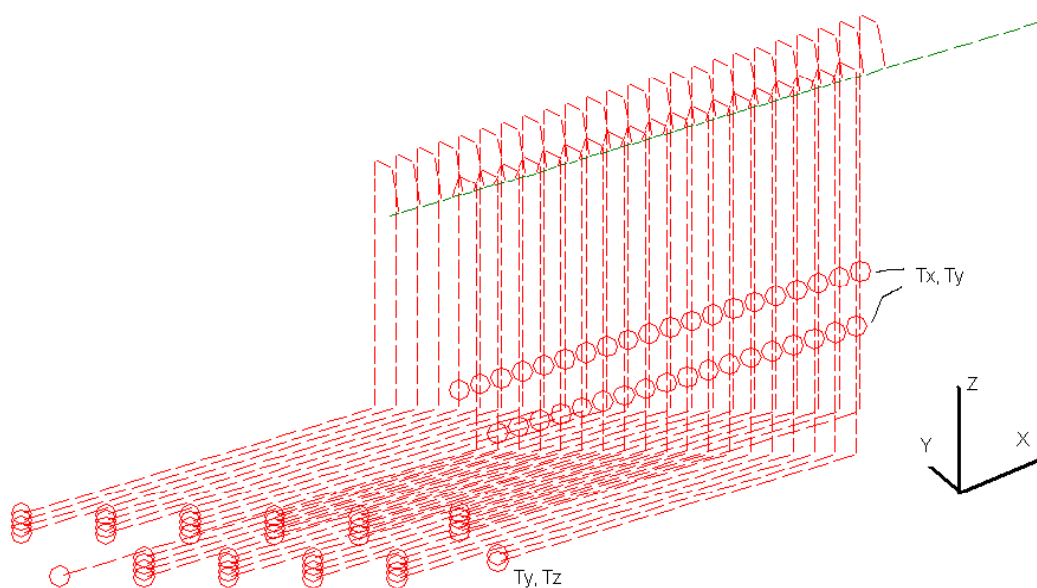

Fig. 5. Finite element model of the GDH with LWC

### Loads for Analysis

The state-of-the-art RELAP5/MOD3 code originally was used for thermo-hydraulic analysis of the GDH guillotine rupture [11]. For the calculations a complete Ignalina NPP RELAP5 model was used [12]. Guillotine rupture was modelled in an appropriate location with a defined break geometry.

For the calculation of reaction force,  $Q_x$ , affecting piping, the following correlation [13] was used:

$$Q_x = (p_k - p_a + \rho_k w_k^2)F + \int_0^l \frac{d}{dt}(\rho w)dl + (p_{wall} - p_a)F_{wall} \quad (1)$$

where,

- $p_k$  - pressure at the break location,
- $p_a$  - outside (atmospheric) pressure,
- $p_{wall}$  - pressure straight after the break location,
- $w_k$  - fluid velocity at the break location,
- $d$  - inner diameter of the pipe,
- $D$  - outer diameter of the pipe,
- $\rho_k$  - fluid density at the break location,
- $l$  - length of the straight pipe,

and  $F = \frac{\pi d^2}{4}$ ,  $F_{wall} = \frac{\pi(D^2 - d^2)}{4}$ .

The first term of the correlation is defined by impulse of flow, which is released through the break. The second term is defined by the impulse change in the analyzed volume. The third term represents the jet force,  $p_{wall}$ , to the wall cross-section after the break. The main contributor to the reaction force  $Q_x$  is the first term.

All the required parameters were obtained from the RELAP5 code. In addition, the second term of the correlation was calculated by a newly introduced function specifically written in the RELAP5 code for this purpose. Dynamic loading on the ruptured pipe is presented in Fig. 6. Maximum load was achieved instantly after the break.

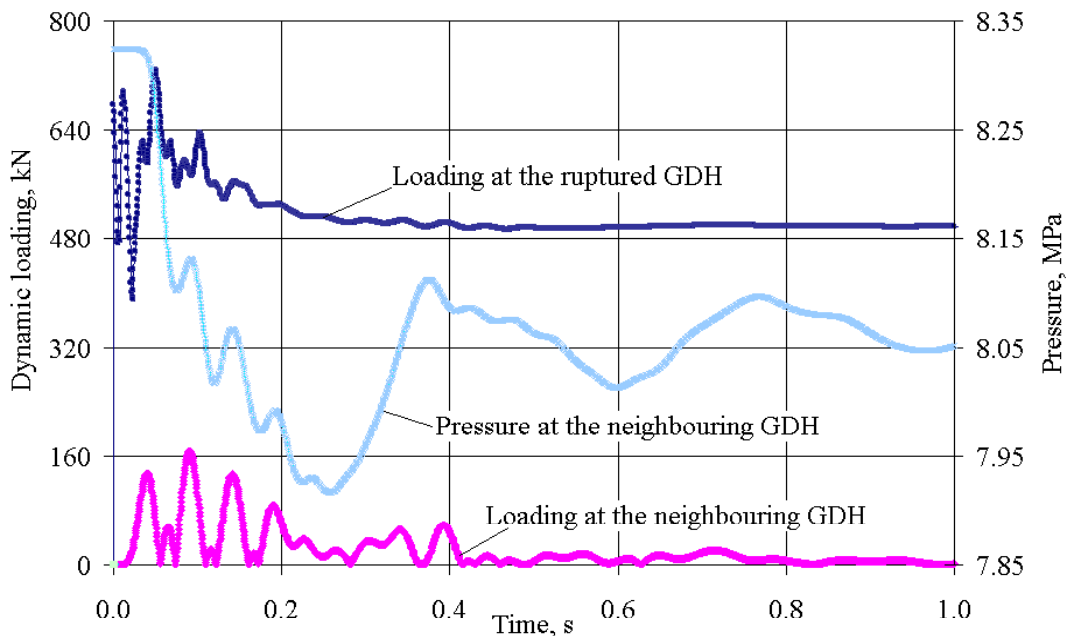

Fig. 6. Dynamic loading at the ruptured and neighboring GDH, and pressure at the neighboring GDH due to guillotine rupture

In the case of analysis “GDH impact on adjacent GDH” the axial dynamic loading and internal pressure are present in the target GDH pipe. Dynamic loading and pressure of the target pipe are shown in Fig. 6.

Possible disposition of pipe components after the guillotine break is presented in Fig.7. The direction of jet thrust force (F) was assumed perpendicular to the GDH axis and directed to the other GDH pipe (first case of analysis) and the wall of the compartment (second case of analysis). This assumption of selected force magnitude and direction is conservative. The jet thrust force cannot be bigger than it is assumed for transient analysis of a guillotine GDH break. The transverse loading is applied from the beginning of the break throughout the motion, which takes the whipping GDH past one diameter of the GDH cap. After that the water can freely exit the GDH without exerting a transverse force component on the end of the pipe.

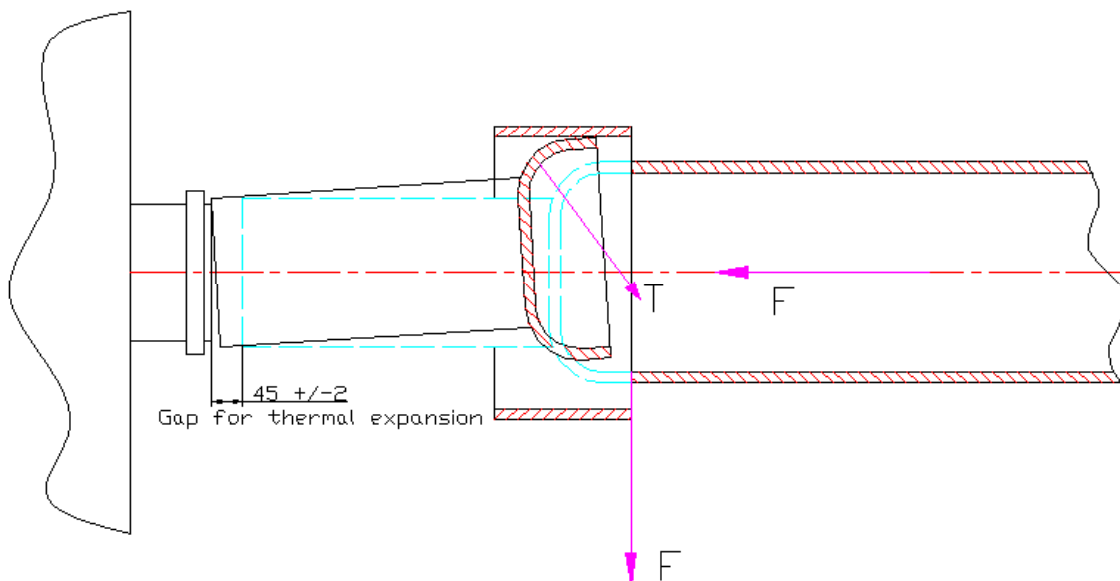

Fig. 7. View after GDH rupture

The mass of water in the pipelines is accounted for by concentrated masses in the models. The whipping process takes a short time, approximately 0.1 sec. Therefore, the effect of gravity is negligible and gravity was not taken into account in the analysis.

## RESULTS OF STRUCTURAL ANALYSIS

The aim of the analysis was to evaluate:

- Structural integrity of adjacent GDH after impact;
- Structural integrity of impacted wall;
- Structural integrity of GDH supporting wall.

As the dynamic motion of the ruptured GDH pipe proceeds, it is necessary to estimate the beginning of the impact, the time when the maximum impact force occurs. Observation of the impact history deals with analysis of large amount of information about displacements and stress state in impacting and impacted objects. The results are presented at the time of the maximum contact stresses using ALGOR Superview [14].

Results are presented as pictures where legend shows the numerical value of the distributed quantity (displacements in meters and stresses in Pascal). The worst stress in pipe models means a combination of axial and bending stresses [14]:

$$\sigma_{\text{worst}} = |\sigma_a| + |\sigma_{b2}| + |\sigma_{b3}| \quad (2)$$

Here  $\sigma_a = P/A$  is the axial stress;  $\sigma_{b_2} = M_2/S_2$  is the bending stress with respect to axis 2 ( $M_2$  – bending moment with respect to 2, and  $S_2$  – sectional modulus with respect to axis 2);  $\sigma_{b_3} = M_3/S_3$  is the bending stress with respect to axis 3.

In the case of GDH pipe rupture the flow of water and steam passes from the drum separator through the fuel channel (cooling of fuel channel) to the LWC pipes. Water flow to the drum separator is going through the unaffected GDH. In the loop there are 20 GDH. Therefore, the failure of LWC pipe is not important for reactor safety. The stress condition of the GDH pipes is presented in this paper, however there are no comments concerning the integrity of these pipes.

#### Results of GDH Impact on Adjacent GDH

This analysis of the guillotine ruptured GDH impact on the adjacent GDH pipe pertains to the model described as “Combined Model of GDH Pipes, Concentrated Masses of Isolation and Control Valve, Connected LWC pipes, and Concrete Walls”. The displacement and velocity of the end of ruptured GDH are presented in Fig. 8. Calculated results show the occurrence of impact under the applied load. The ruptured GDH impacts the neighboring GDH pipe after 0.01806 s (see Fig. 9).

The calculated results in Figs. 10 and 11 are presented at the instant of maximum contact force. The maximum stress was obtained in the connected LWC pipes and was 642 MPa (Fig. 10a). The maximum stress in the ruptured GDH is 268 MPa (middle of ruptured GDH-Fig.10b). Maximum stress in the impacted GDH pipe is 139 MPa. The pipe material yield limit (177 MPa) was exceeded in the ruptured GDH pipes and the connected LWC pipes. The strength limit (412 MPa) was also exceeded in the connected LWC.

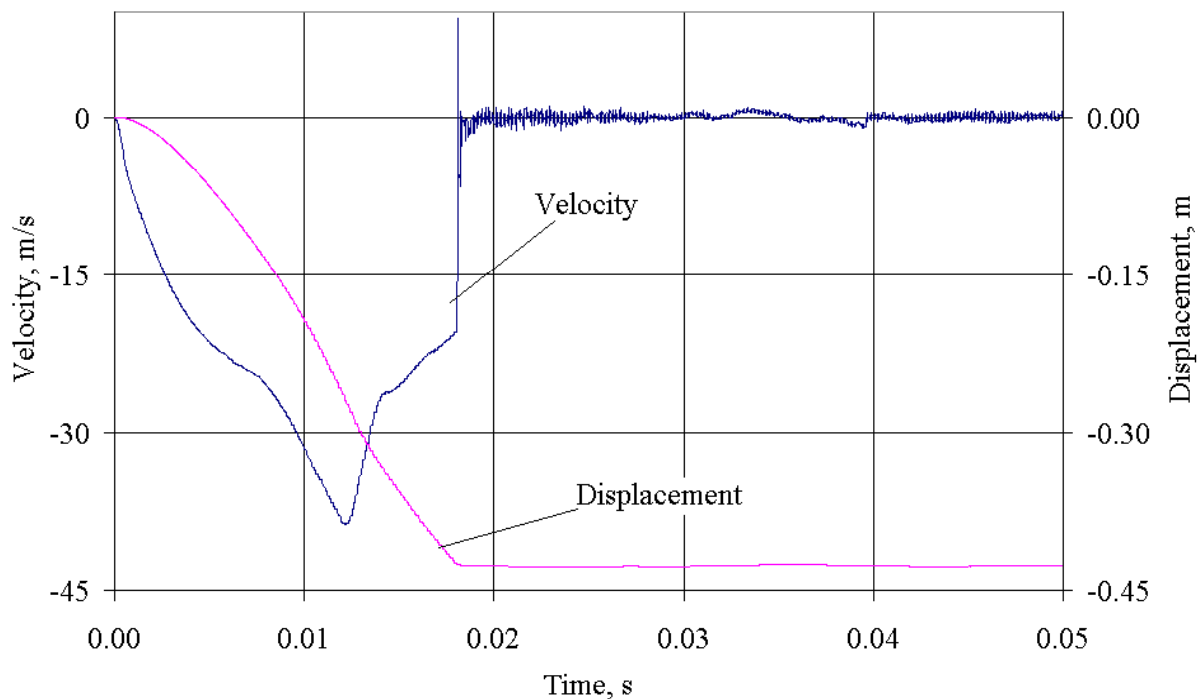

Fig. 8. Displacement and velocity of the end of the ruptured GDH pipe

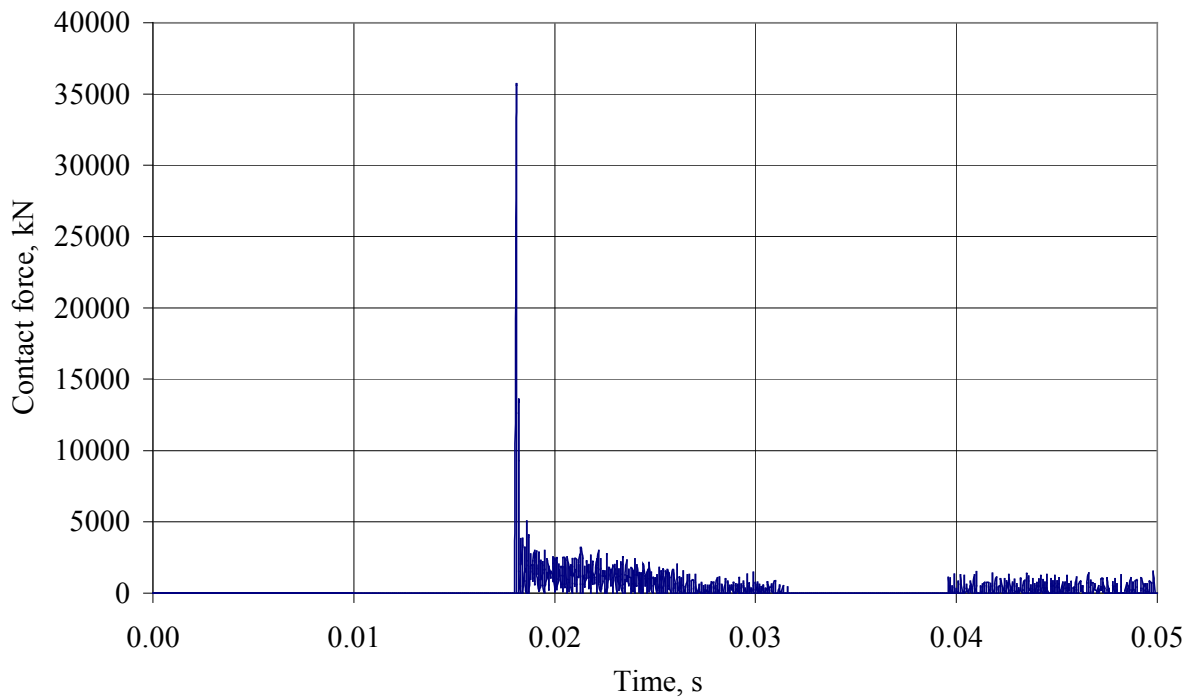
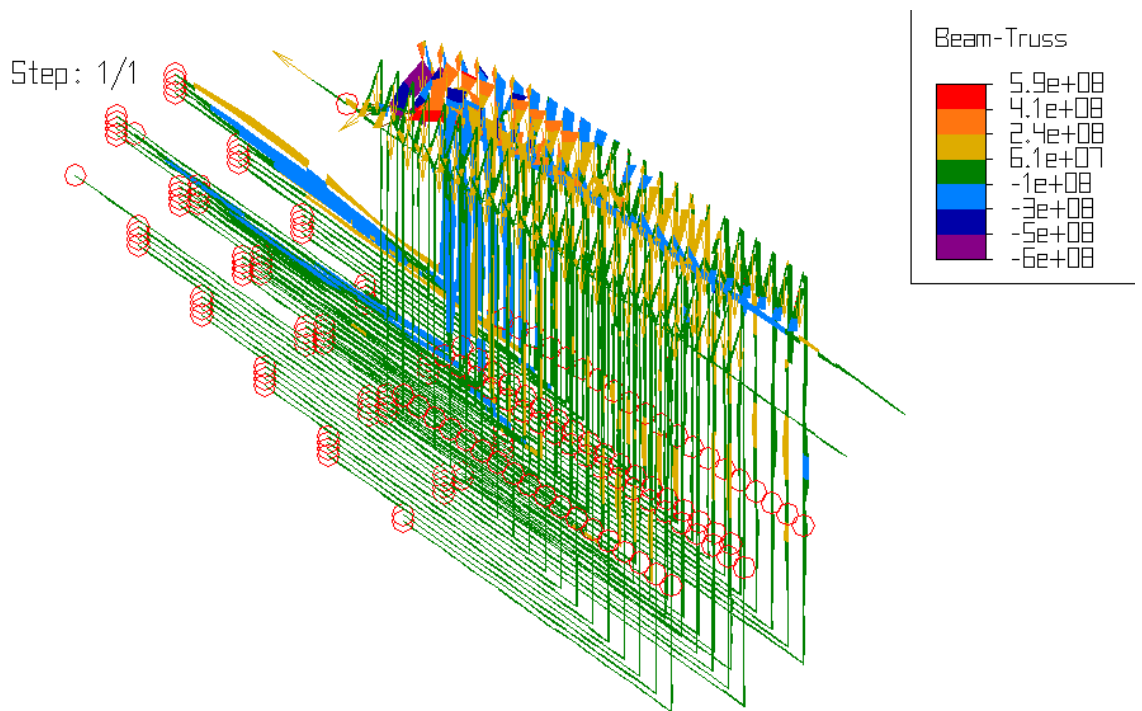
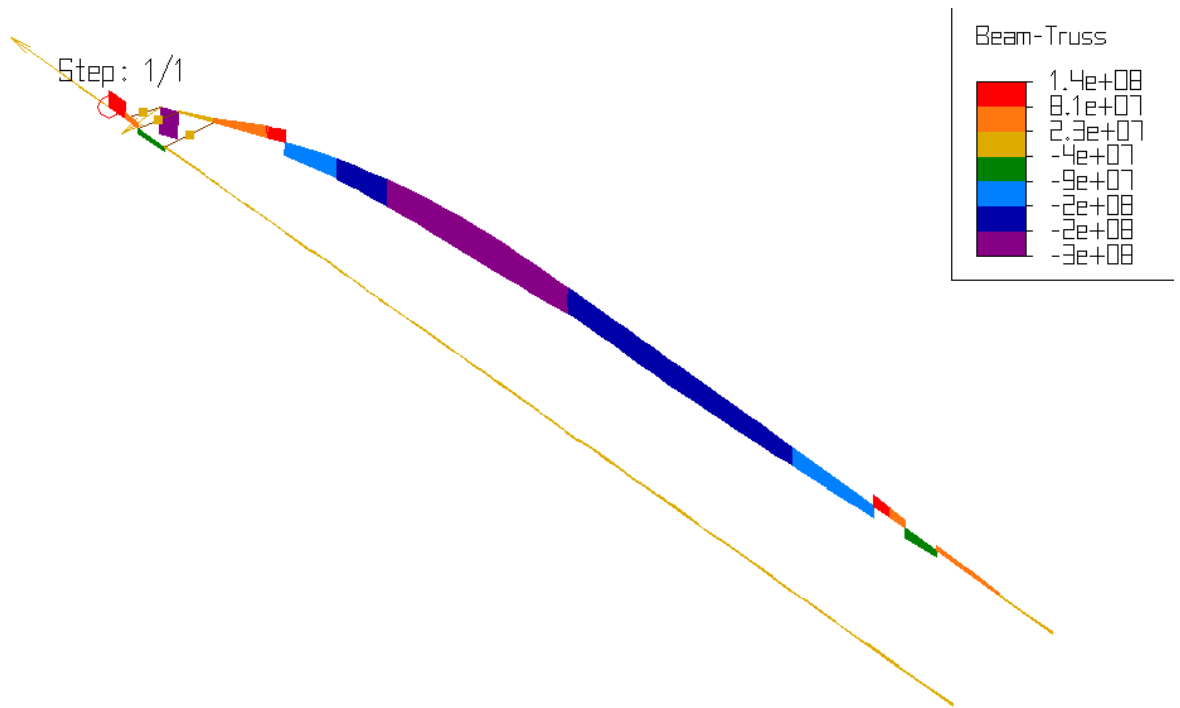

Fig. 9. Contact force between the ruptured GDH and impacted GDH pipes

The maximum stress in reinforcing bars of the wall was 74 MPa (Fig.11). The rebar yield limit (392 MPa) was not exceeded. The maximum displacement in the GDH supporting wall after guillotine rupture is 1.09 mm (Fig. 12). The concrete wall supporting the GDH experiences a wide area of cracking (but not crushing) of the external layer of concrete near the moving pipe support.



a)



b)

Fig. 10. The worst stress (in Pa) distribution in the GDH pipes after guillotine rupture at time of 0.01806s: a – the stresses in LWC are shown, b - the stresses in LWC are not shown

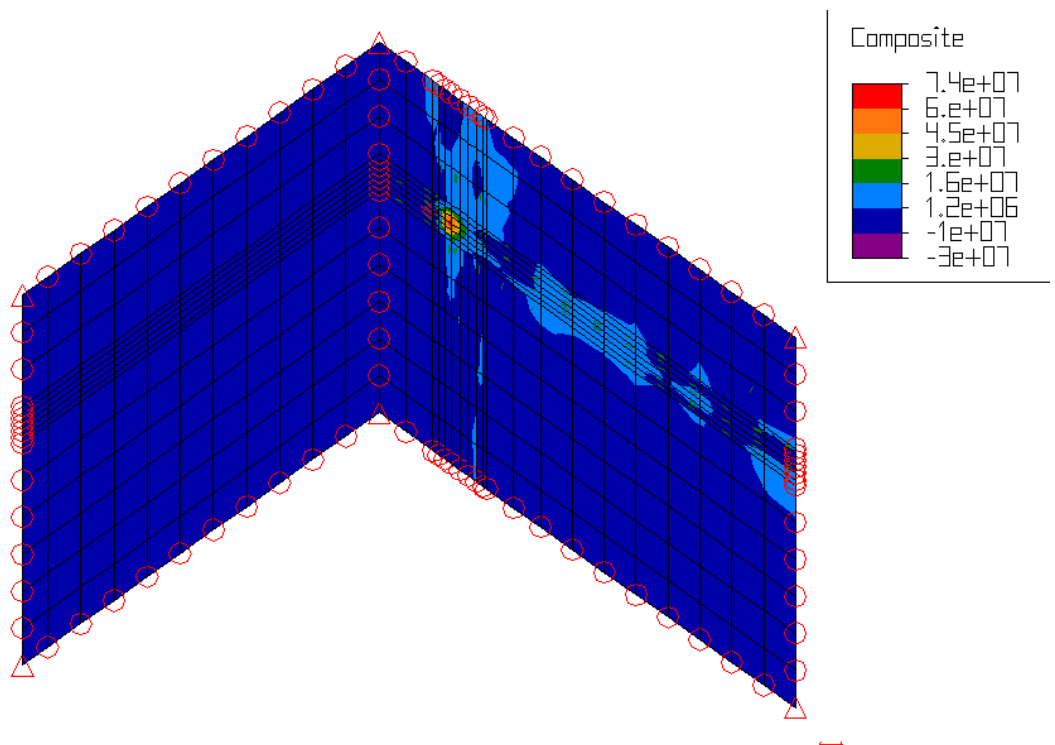

Fig. 11. Maximum principal stress distribution in the GDH-supporting wall after guillotine rupture at time of 0.01806 s.

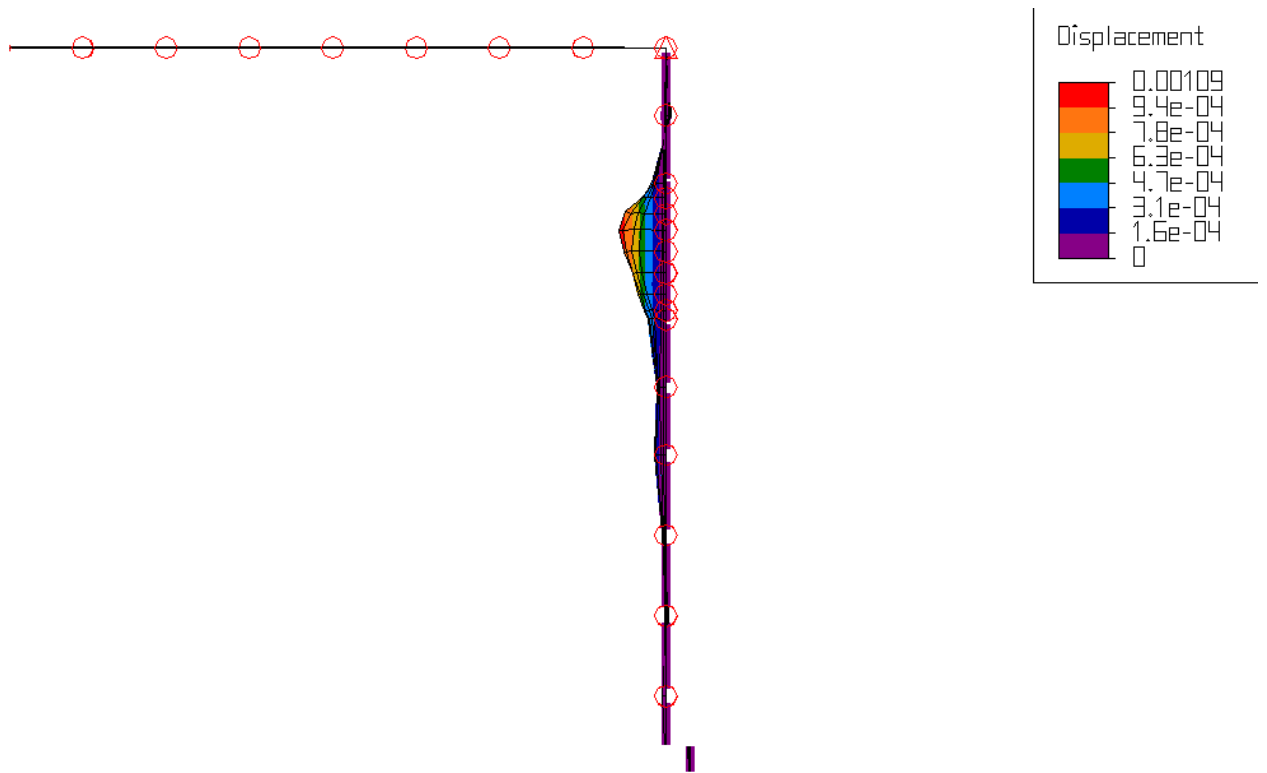

Fig. 12. Displacement (in meters) distribution in the GDH-supporting wall around pipe support after the guillotine rupture at time of 0.01806 s.

The variation of stresses in concrete and reinforcement bars of the GDH-supporting wall (the adjacent element to node of pipe support in the wall) during whipping of GDH is presented in Fig. 13 and Fig. 14.

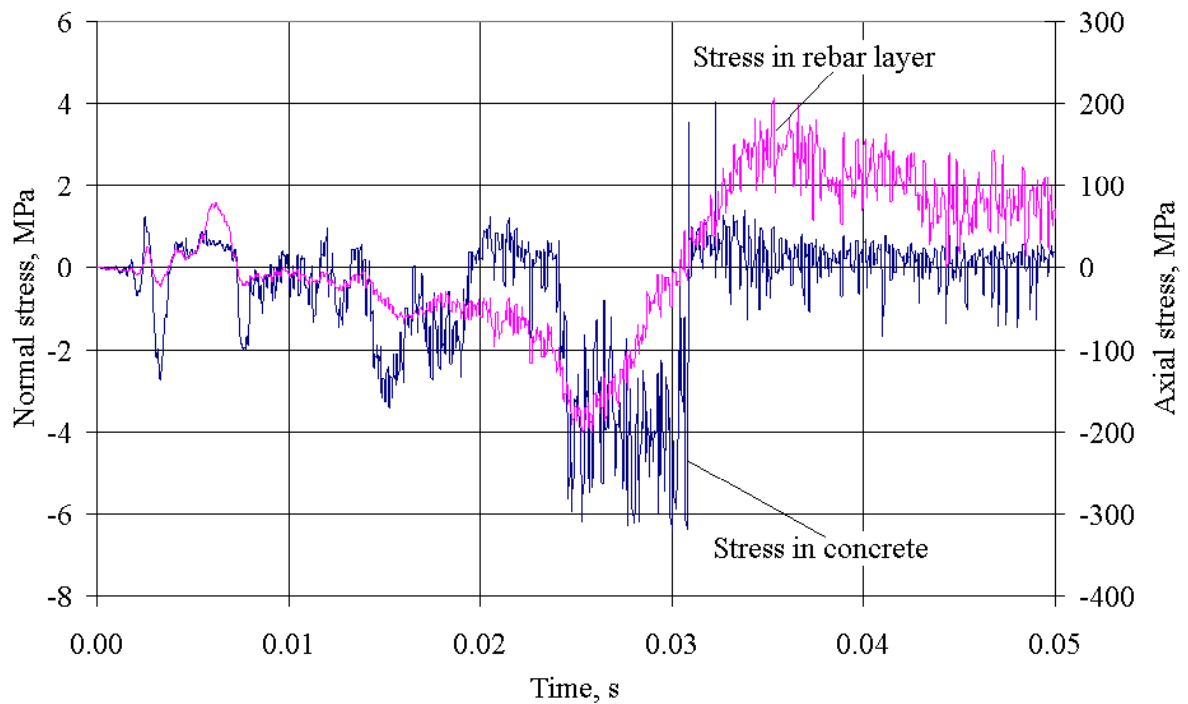

Fig. 13. Normal stress in the element and axial stress in the element of GDH support wall in concrete and rebar layer

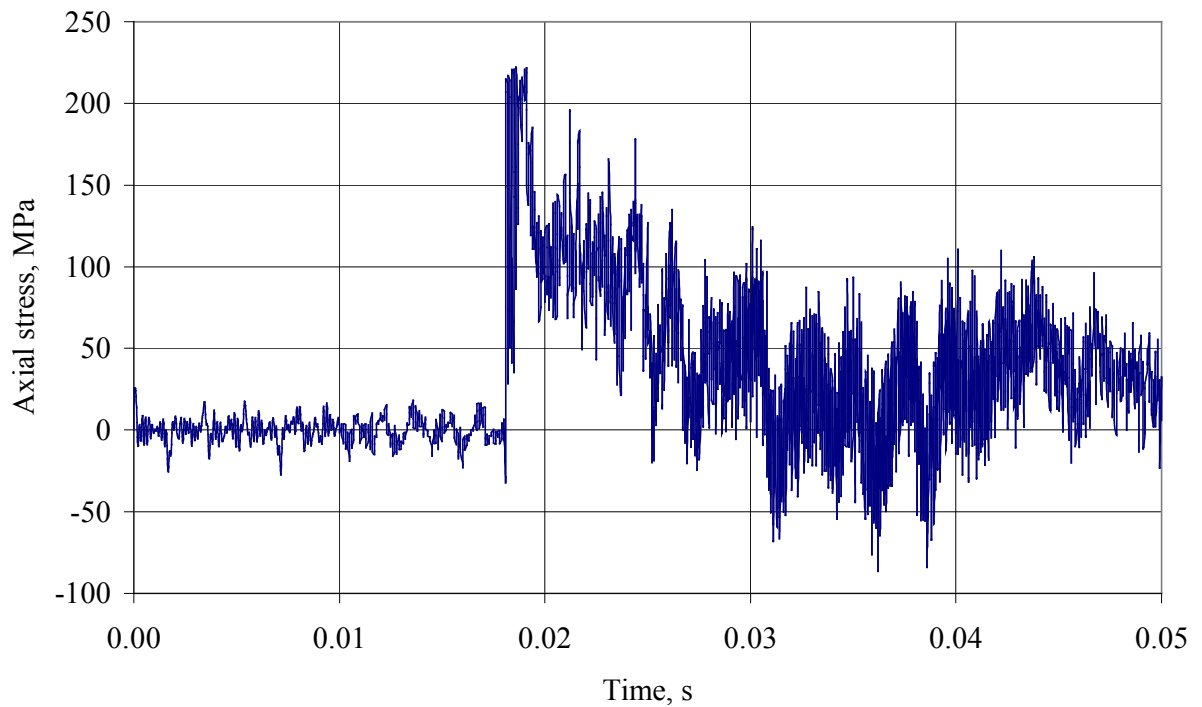

Fig. 14. Stress along the x-axis in the impacted element of the GDH

The maximum normal stress in concrete is 3.92 MPa (tension) and 6.36 MPa (compression). The concrete limit for tension (1.5 MPa) was exceeded and compression (17 MPa) was not exceeded due to whip of the ruptured GDH. It means, the tension evaluation is completed and the cracks in concrete start to open, but element has resistance for compression. The maximum stresses are 202 MPa in reinforcing bars. The rebar yield limit (392 MPa) was not exceeded due to whip of the ruptured GDH. The variation of stress along the x-axis in the impacted element of the GDH during whipping is presented in Fig. 13. The maximum stresses in impacted GDH pipe are 222 MPa. The yield limit of pipe material was exceeded, however the strength limit was not exceeded.

Calculated stress level in impacted GDH pipe is below the material strength limit. The strength limit was exceeded in the connected LWC. A more detailed analysis of these piping could be done for structural integrity if the need exists. The GDH-supporting wall has cracks and crushing of one layer of concrete, but the reinforcement is not damaged. It means, that structural integrity of neighboring GDH pipes and GDH supporting wall will not be destroyed in case of guillotine rupture of the GDH.

#### Results of GDH Impact on Adjacent Wall

This analysis of the guillotine-ruptured GDH impact on adjacent wall pertains to the model described as “Combined Model of the GDH Pipes, Concentrated Masses of Isolation and Control Valve, Connected LWC pipes, and Concrete Walls”. The displacement and velocity of the end of the ruptured GDH are presented in Fig. 15. Calculated results show the occurrence of impact under applied load. The ruptured GDH impacts the neighboring GDH pipe at 0.12624 s (see Fig. 16).

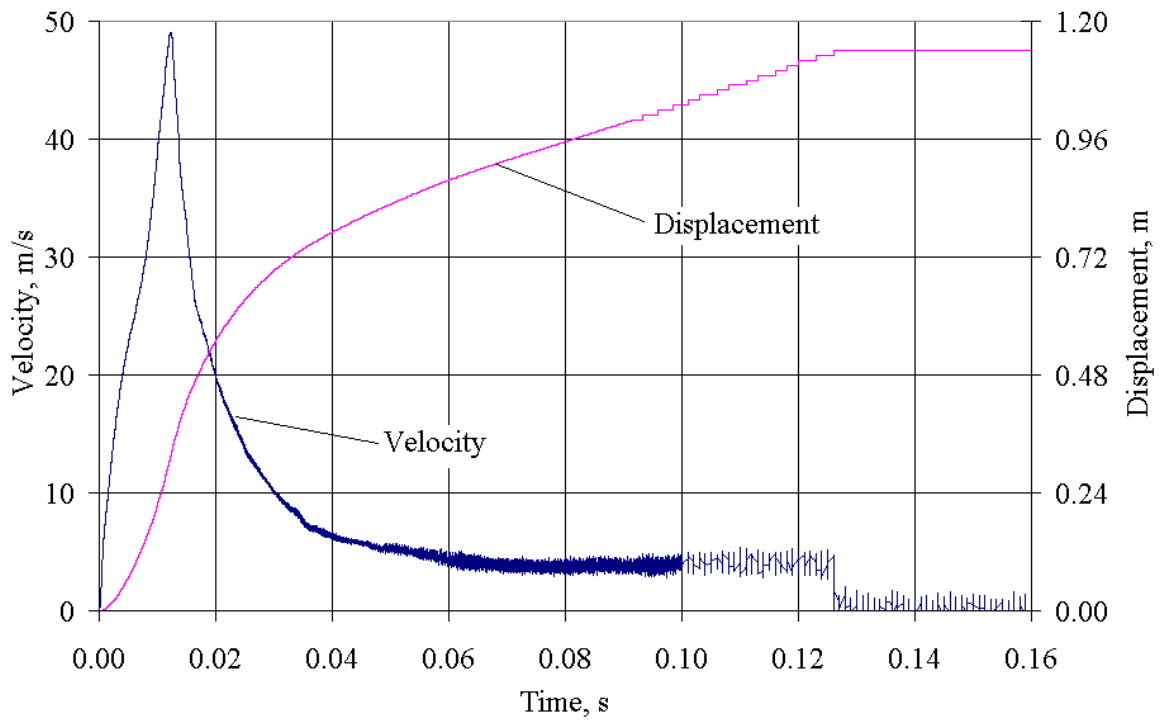

Fig. 15. Displacement and velocity of end of the ruptured GDH pipe

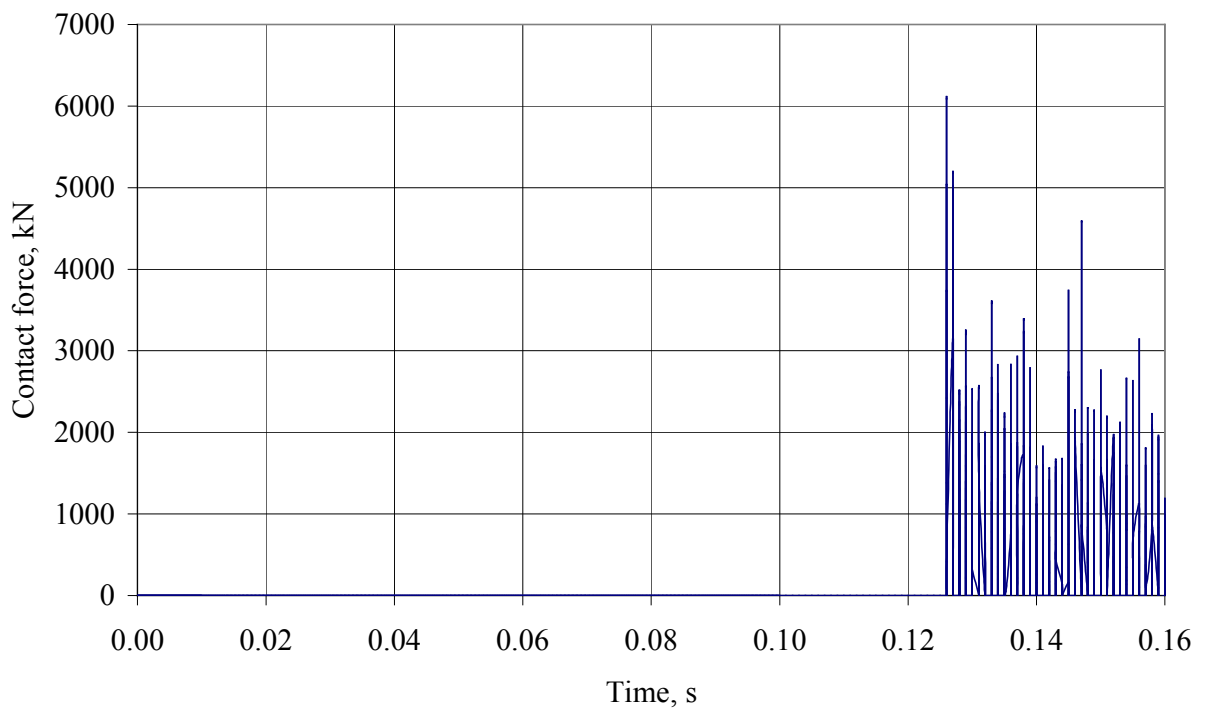
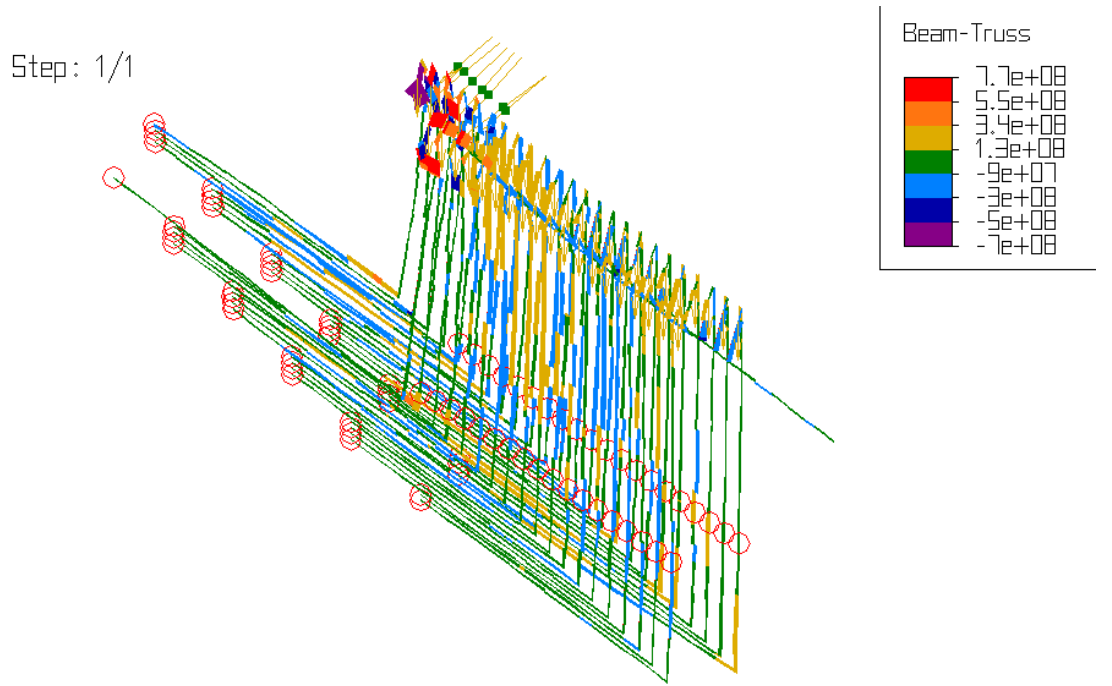
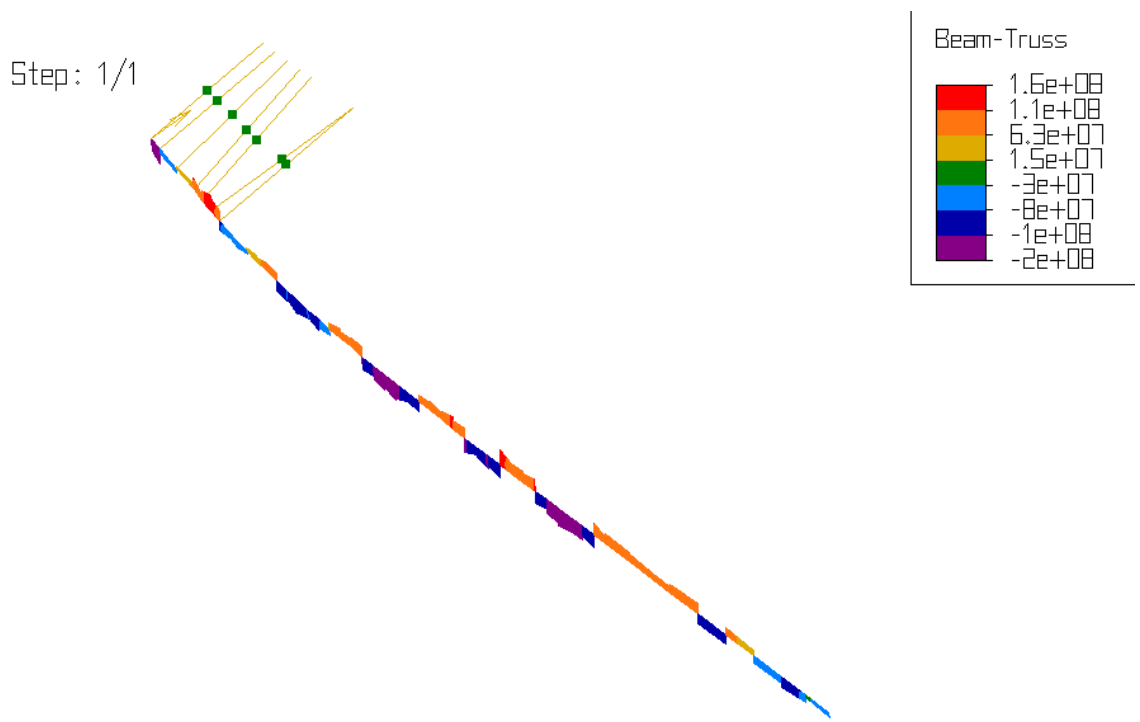

Fig. 16. Contact force between the ruptured GDH and the impacted wall

The calculated results are presented using ALGOR Superview [14] at the time of maximum contact force. The maximum stresses were obtained in the connected LWC pipes and comprise 768 MPa (Fig. 17a). The maximum stress in the ruptured GDH is 174 MPa (end of ruptured GDH Fig. 17b). The pipe material yield limit (177 MPa) and the strength limit (412 MPa) was exceeded in the connected LWC pipes.



a)



b)

Fig. 17. The worst stress (Pa) distribution in the GDH pipes after the guillotine rupture at 0.12624 s: a – the stresses in LWC are shown, b - the stresses in LWC are not shown

Maximum stresses are 195 MPa in the reinforcing bars of the impacted wall (Fig. 18). Maximum stresses are 181 MPa in the reinforcing bars of the supporting wall (Fig. 18). The rebar yield limit (392 MPa) was not exceeded in both walls. The maximum displacement in the GDH-supporting wall after the guillotine rupture is 3.68 mm and in the impacted wall is 0.42 mm (Fig. 19). The pipe-impacted and supporting concrete walls experience a wide area of cracking. Crushing of external layer of concrete is also indicated. A representative cracking pattern of the impacted wall is shown in Fig. 20.

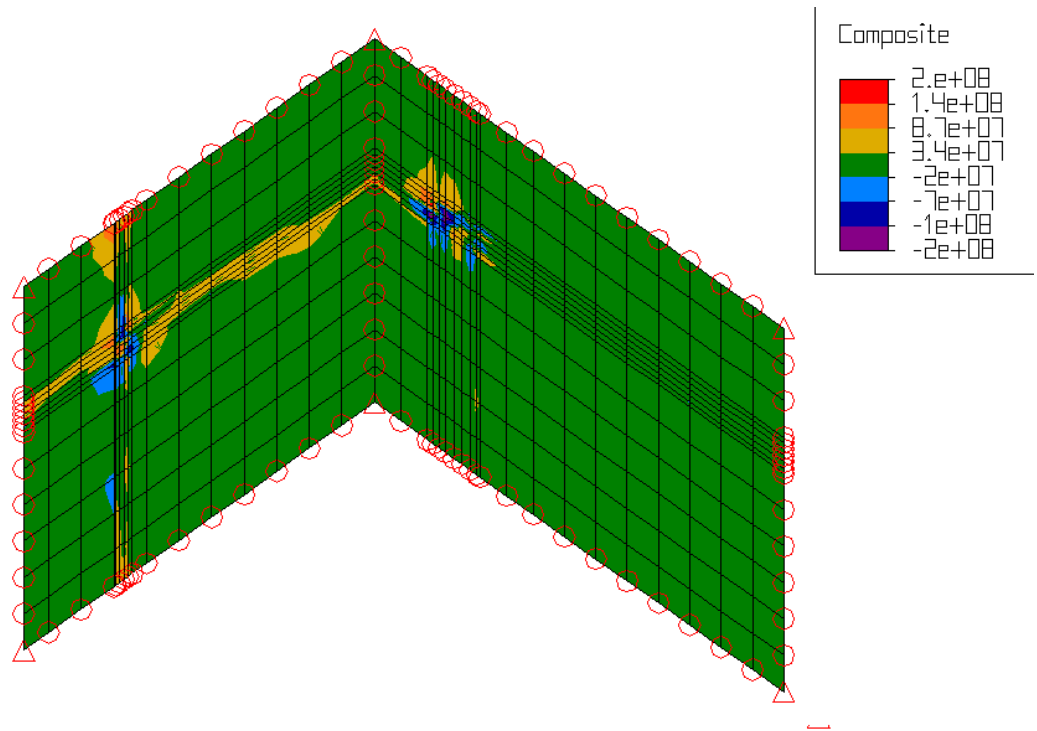

Fig. 18. Maximum principal stress (Pa) distribution of impacted wall and the GDH-supporting wall after guillotine rupture at 0.12624 s.

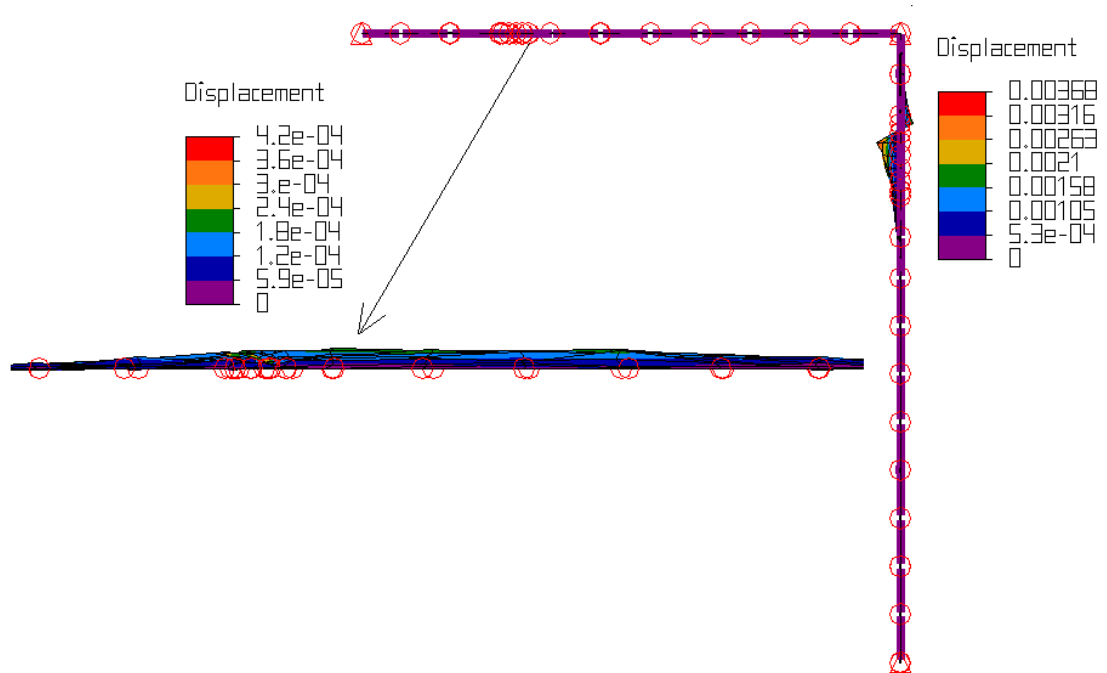

Fig. 19. Displacement (meters) distribution of the impacted wall (0.42 mm) and the GDH-supporting wall (3.68 mm) after guillotine rupture at 0.12624 s.

The variation of stresses in concrete and reinforcement bars of the GDH-impacted wall and the GDH-supporting wall during the whipping of the GDH are presented in Fig. 21 and Fig. 22. Maximum normal stress in concrete of the impacted wall is 5.77 MPa (tension) and 17.0 MPa (compression), Fig. 21. Maximum normal stress in concrete of the supporting wall is 6.17 MPa (tension) and 11.1 MPa (compression), Fig. 22. The concrete limit for tension (1.5 MPa) was exceeded in both, the impacted and the supporting walls. The concrete limit for compression (17 MPa) was not exceeded in either wall.

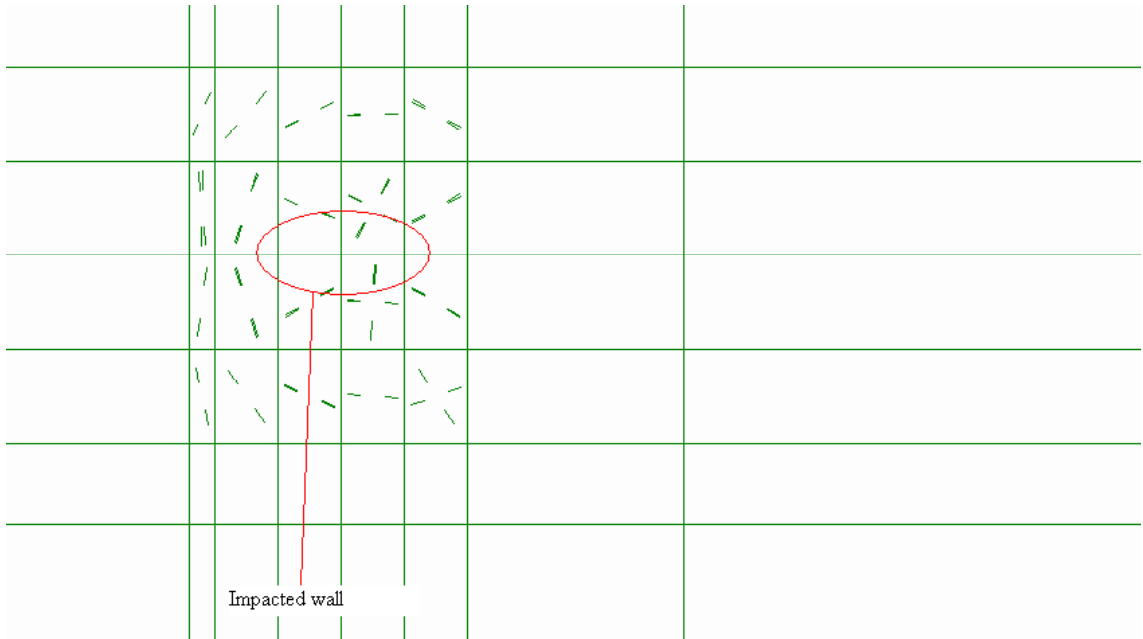

Fig. 20. A representative cracking pattern of the impacted wall

Maximum stress of 393 MPa occurs in the reinforcing bars of the impacted wall (Fig. 21), while a maximum stress of 392 MPa occurs in the reinforcing bars of the supporting wall (Fig. 22). The rebar yield limit (392 MPa) was not exceeded in the supporting wall during whipping of the ruptured GDH. The rebar yield limit was exceeded in the impacted wall, but the strength limit was not exceeded.

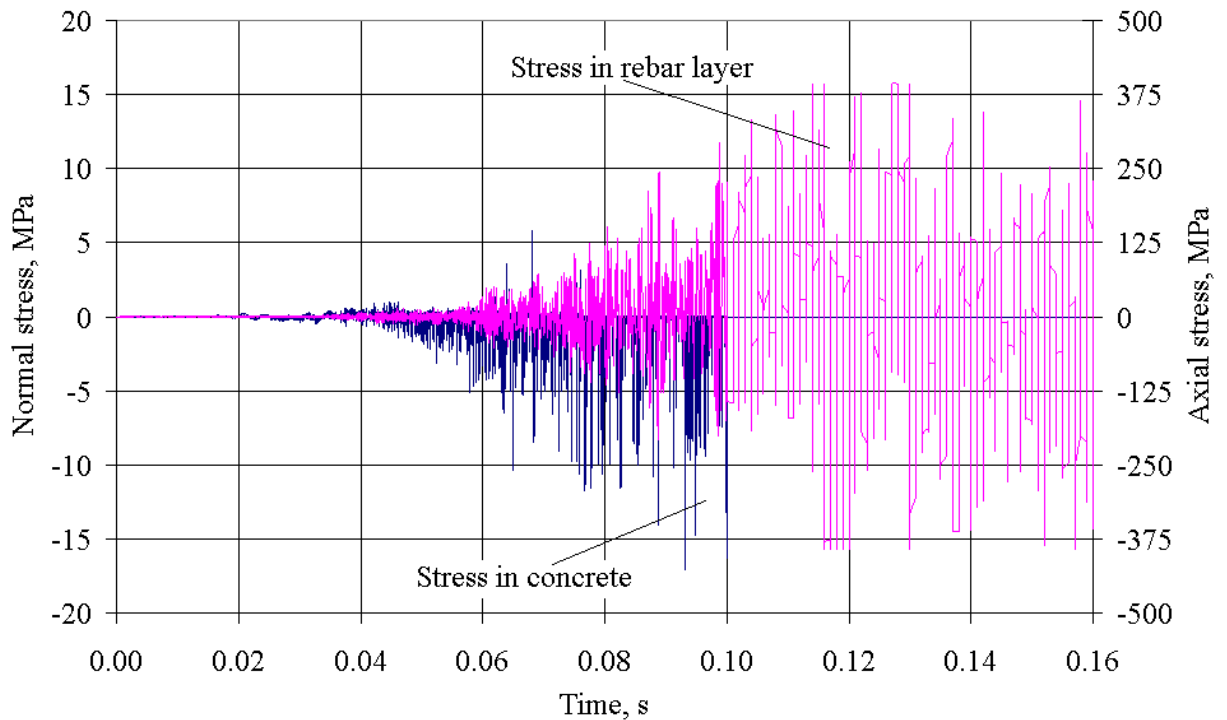

Fig. 21. Normal stress in concrete and axial stress in rebar layer in the element of the impacted wall

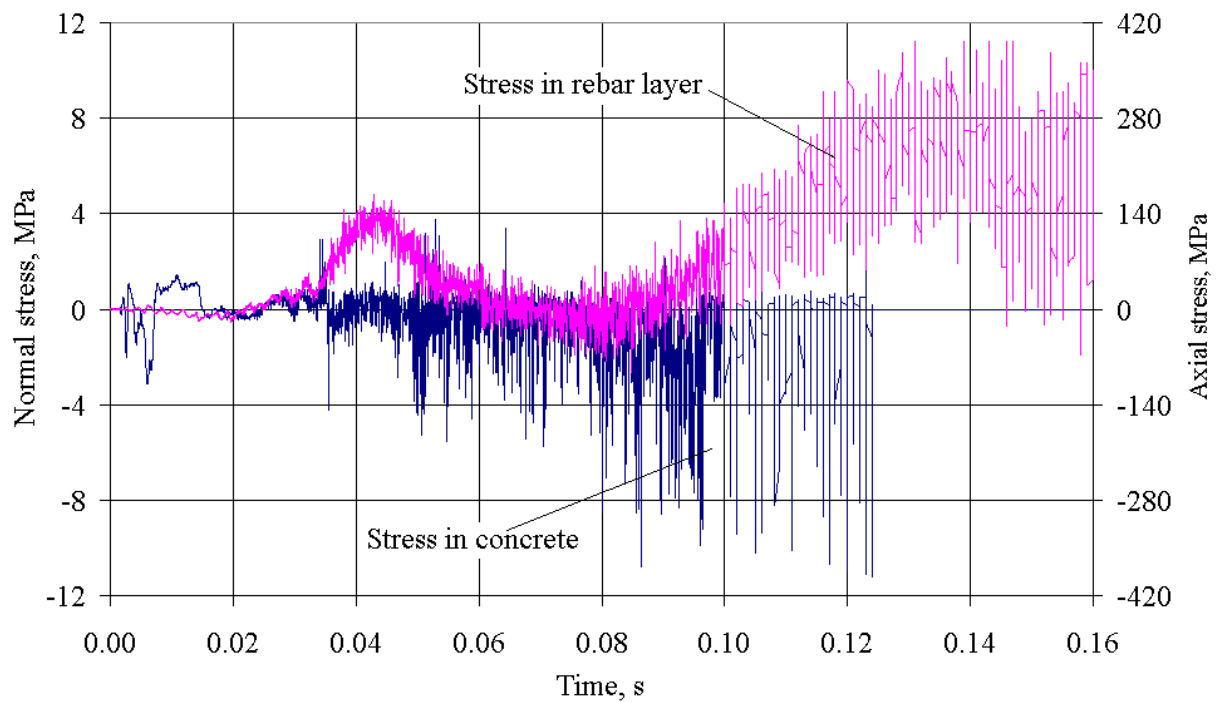

Fig. 22. Normal stress in concrete and axial stress in rebar layer in the element of the GDH-support wall

Calculated stress level in ruptured GDH pipe is below the material strength limit. The strength limit was exceeded in the connected LWC. A more detailed analysis of this piping system could be done for structural integrity if the need is warranted. The impacted wall and the GDH-supporting wall have cracks and crushing of one layer of concrete, but reinforcement is not damaged. This means that the structural integrity of impacted wall and the GDH supporting wall will not be destroyed in case of guillotine rupture of the GDH.

## SUMMARY AND CONCLUSION

The transient analysis of the GDH guillotine break and impact to neighboring pipes and walls was carried out.

The completed analysis shows:

- The occurrence of impact under applied load in both cases;
- Calculated stress level in the GDH target pipe and the pipe in motion is below the material strength limit, except in the LWC pipes of the whipping GDH pipe;
- The GDH pipe-supporting wall has cracks and crushing of one layer of concrete, but reinforcement is not damaged;
- The impacted wall has cracks and crushing of one layer of concrete, but reinforcement was not damaged.

## ACKNOWLEDGMENTS

This work was supported by the U.S. Department of Energy, National Nuclear Security Administration. The authors from LEI would like to acknowledge the support and access to the newest NEPTUNE code provided by the US DOE and ANL. The authors also want to extend thanks to the administration and technical staff at the Ignalina NPP, for providing information regarding operational procedures and operational data.

The U.S. Government makes no endorsement of the results of this work.

## REFERENCES

1. Review of the Ignalina NPP Safety Analysis Report, RISKAUDIT, Report No. 55, 1997.
2. Kulak, Ronald F. and Narvydas, Evaldas, "Validation of the NEPTUNE Computer Code for Pipe Whip Analysis," Transactions 16<sup>th</sup> International Conference on Structural Mechanics in Reactor Technology, Washington DC, August 12-17, 2001, Paper JP01/3.
3. Belytschko, T., Lin, J.I., and Tsay, C.S., "Explicit Algorithms for Nonlinear Dynamics of Shells", Computer Methods in Applied Mechanics and Engineering, Vol. 42, 1984, pp. 225-251.
4. Kulak, R.F. and Fiala, C., "Neptune a System of Finite Element Programs for Three Dimensional Nonlinear Analysis", Nuclear Engineering and Design, 106, 1988, pp. 47-68.
5. Belytschko, T., Schwer, L., "Large Displacement, Transient Analysis of Space Frame," International Journal for Numerical Methods in Engineering, Vol., 11, 1977, pp. 65-84.
6. Narvydas, E. and Kulak, R.F., "Modeling of Pipework, Subjected to Impact Loads," MECHANIKA-2001, Proceedings of the International Conference, Kaunas University of Technology, Lithuania, April 5-6, 2001, pp. 441-447.
7. Kulak, R.F., "Adaptive Contact Elements for Three-Dimensional Fluid-Structure Interfaces", Eds., C.Y. Wang and T.B. Belytschko, Fluid-Structure Dynamics. ASME Publication PVP-Vol. 98-7, 1985, pp. 159-166.
8. Kulak R.F., "Adaptive Contact Elements for Three-Dimensional Explicit Transient Analysis", Computer Methods in Applied Mechanics and Engineering, 72, 1989, pp. 125-151.
9. Norms and Rules for Buildings SNiP 2.03.01-84. (in Russian).
10. Norms for the calculation of strength of the equipment and the pipelines of nuclear power installations (PNAE G-7-002-86) / Regulatory authority for the control of nuclear power of the USSR. - Moscow, Energoatomizdat, 1989, (in Russian).
11. The RELAP5 Code Development Team, RELAP5/MOD3 Code Manual, Volume 1, Code Structure, System Models, and Solution Methods, NUREG/CR-5535, INEL-95/0174, 1995.
12. Kaliatka, A., Uspuras, E. Benchmark analysis of main circulation pump trip events at the Ignalina NPP using RELAP5 code, Nuclear Engineering and Design 202, Elsevier Science S.A., 2000, pp. 109-118.
13. Birbraer, A. N. Shulman, S. G., Strength and reliability of NPP constructions for special dynamic forces, Moscow Energoatoizdat, 1989. (in Russian).
14. Algor Finite Element Analysis System, ALGOR Instruction Manuals. Algor, Inc. Pittsburgh, 2000.